



2729GN-500

500 Watts - 65 Volts, 100 μ s, 10%
Radar 2700 - 2900 MHz

GENERAL DESCRIPTION

The 2729GN-500 is an internally matched, COMMON SOURCE, class AB GaN on SiC HEMT transistor capable of providing over 12dB gain, 500 Watts of pulsed RF output power at 100 μ s pulse width, 10% duty factor across the 2700 to 2900 MHz band. The transistor has internal pre-match for optimal performance. This hermetically sealed transistor is specifically designed for S-band radar applications. It utilizes gold metallization and eutectic attach to provide highest reliability and superior ruggedness.

CASE OUTLINE

55-KR
Common Source

ABSOLUTE MAXIMUM RATINGS

Maximum Power Dissipation

Device Dissipation @ 25°C 1000 W

Maximum Voltage and Current

Drain-Source Voltage (V_{DSS}) 150 V

Gate-Source Voltage (V_{GS}) -8 to +0 V

Maximum Temperatures

Storage Temperature (T_{STG}) -55 to +125 °C

Operating Junction Temperature +250 °C

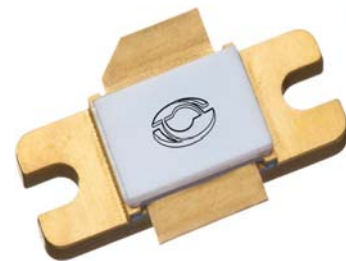

ELECTRICAL CHARACTERISTICS @ 25°C

Symbol	Characteristics	Test Conditions	Min	Typ	Max	Units
Pout	Output Power	Pout=500W, Freq=2.7, 2.8, 2.9 GHz	500	520		W
Gp	Power Gain	Pout=500W, Freq=2.7, 2.8, 2.9 GHz	11.5	12.16		dB
η_d	Drain Efficiency	Pout=500W, Freq=2.7, 2.8, 2.9 GHz	47	53		%
R/L	Input Return Loss	Pout=500W, Freq=2.7, 2.8, 2.9 GHz	-8			dB
VSWR-T	Load Mismatch Tolerance	Pout=500W, Freq= 2.8 GHz			3:1	
Θ_{jc}	Thermal Resistance	Pulse Width=100uS, Duty=10%			0.2	°C/W

- Bias Condition: Vdd=+65V, Idq=1000mA peak current (V_{gs} = -2.0 ~ -4.5V typical)

FUNCTIONAL CHARACTERISTICS @ 25°C

$I_{D(Off)}$	Drain leakage current	$V_{gs} = -8V, V_D = 65V$			10	mA
$I_{G(Off)}$	Gate leakage current	$V_{gs} = -8V, V_D = 0V$			8	mA
BV_{DSS}	Drain-source breakdown voltage	$V_{gs} = -8V, I_D = 10mA$	250			V

Issue May 2012



2729GN-500

500 Watts - 65 Volts, 100 μ s, 10%
Radar 2700 - 2900 MHz

Typical Performance Data:

Frequency	Pin (W)	Pout (W)	Id (A)	RL (dB)	Nd (%)	G (dB)
2700 MHz	31.6	531	1.7	-15	50	12.3
2800 MHz	31.6	525	1.61	-16	52	12.2
2900 MHz	31.6	535	1.57	-9.5	56	12.4

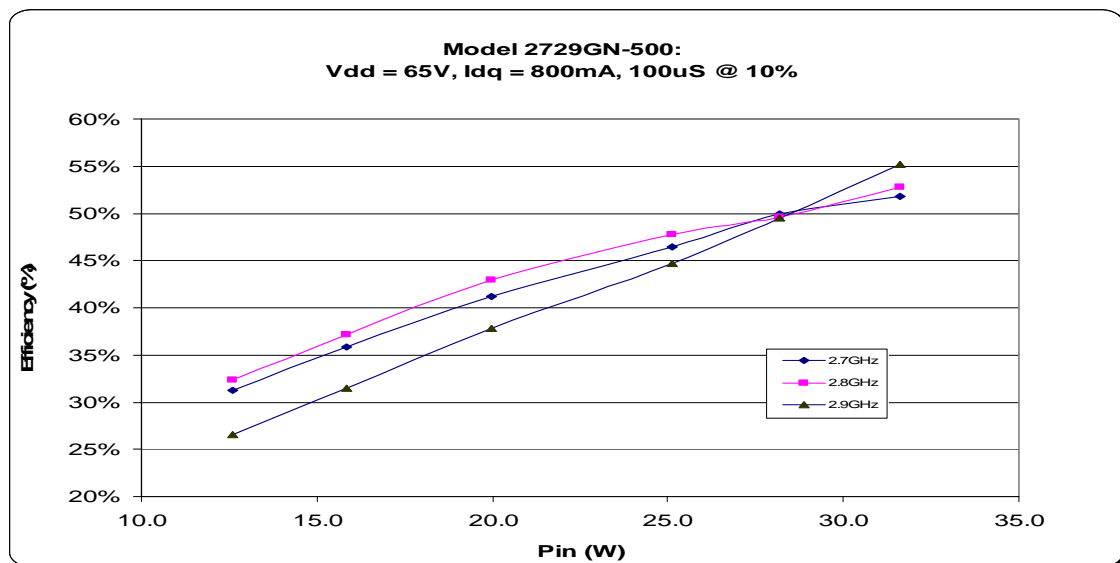
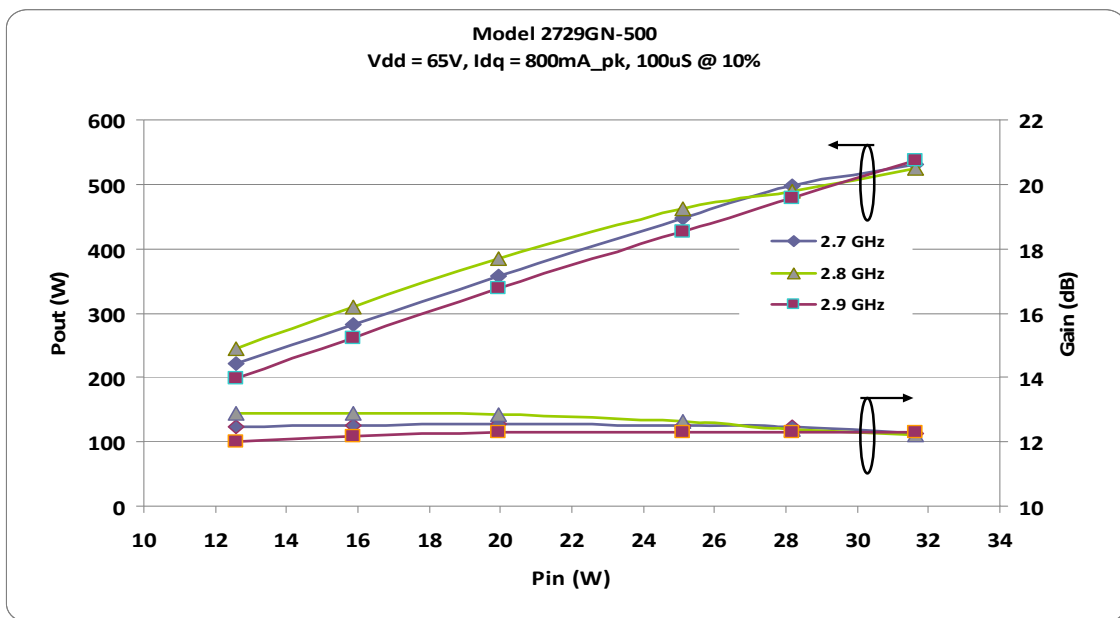



2729GN-500

500 Watts - 65 Volts, 100 μ s, 10%
Radar 2700 - 2900 MHz

Transistor Impedance Information

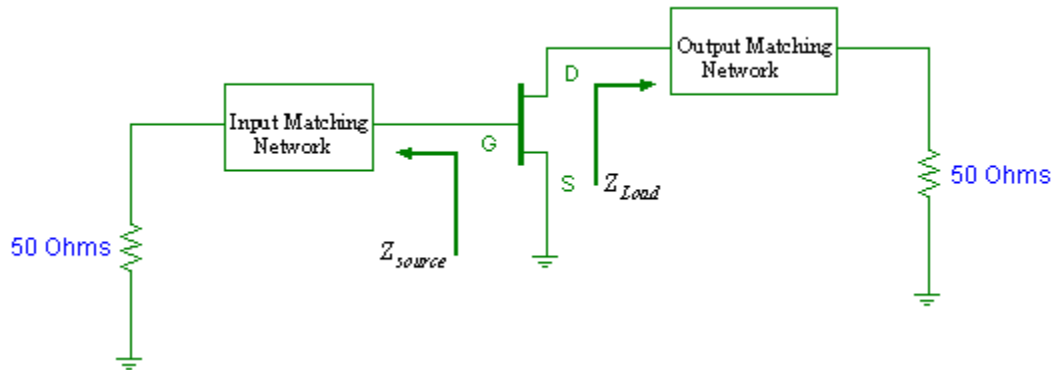

Note: Z_{in} is looking into the input circuit;
 Z_{Load} is looking into the output circuit.

Impedance Data		
Freq (GHz)	Zs	ZI
2.7	4.61 - j11.51	2.83 - j1.33
2.8	3.96 - j10.79	2.72 - j.95
2.9	3.29 - j9.86	2.67 - j.56



2729GN-500

500 Watts - 65 Volts, 100 μ s, 10%
Radar 2700 - 2900 MHz

Test Circuit Diagram

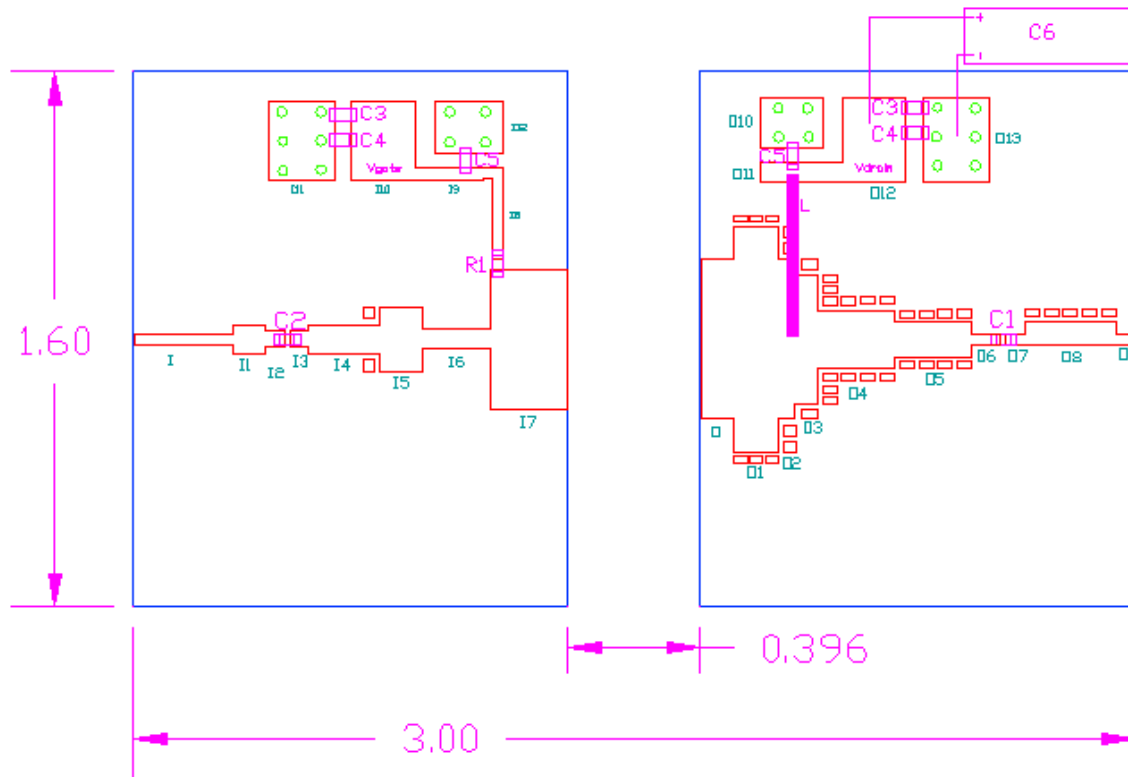

Board Material: Roger Duriod 6006 @ 25 Mil Thickness, Er=6.15

Component List				Input Physical Circuit Layout			Output Physical Circuit Layout		
Item	Description		Value	Item	W (mil)	L (mil)	Item	W (mil)	L (mil)
C1	Chip Cap A size	ATC800A6R8BW250XT	6.8pF	I	35	295	O	476	98
C2	Chip Cap A size	ATC800A8R2BW250XT	8.2pF	I1	88	100	O1	676	130
C3	Chip Cap B size	ATC200B103KW50XT	10,000pF	I2	47	54	O2	476	52
C4	Chip Cap B size	ATC100B102102KW50XT	1000pF	I3	47	54	O3	388	69
C5	Chip Cap B size	ATC100B101FW1000XT	100pF	I4	88	216	O4	175	226
C6	Electrolytic Cap (160V)	Digikey: 493-1396-ND	1000uF	I5	190	128	O5	106	230
R1	Chip Resistor size 0805	ANY	11.5 ohms	I6	60	204	O6	35	90
L	RF Choke 20 AWG Copper wire L=630 mil			I7	420	225	O7	35	58
				I8	35	250	O8	68	270
				I9	35	240	O9	35	55
Note:				I10	230	190	O10	154	190
	Need 2x of C3,C4,C5			I11	230	200	O11	55	245
				I12	150	200	O12	250	190
							O13	250	190



2729GN-500

500 Watts - 65 Volts, 100 μ s, 10%
Radar 2700 - 2900 MHz

55-KR Package Dimension

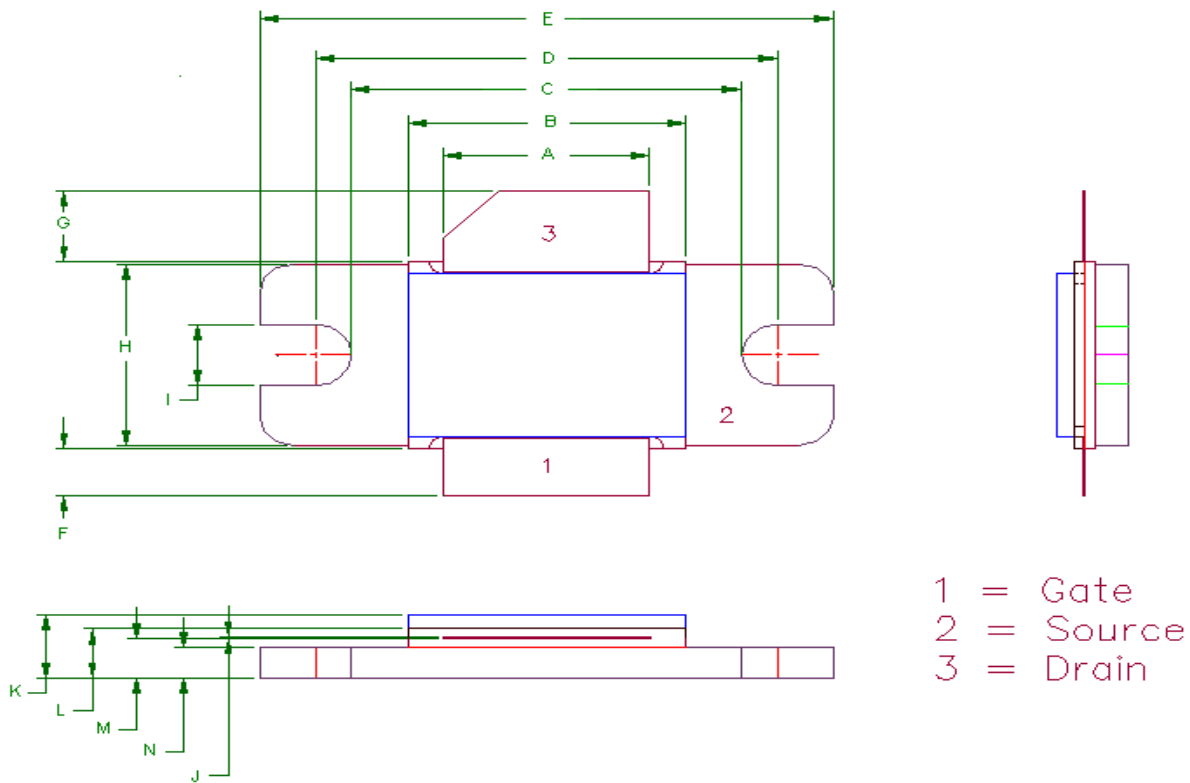

Dimension	Min (mil)	Min (mm)	Max (mil)	Max (mm)
A	370	9.40	372	9.44
B	498	12.65	500	12.7
C	700	17.78	702	17.83
D	830	21.08	832	21.13
E	1030	26.16	1032	26.21
F	101	2.56	102	2.59
G	151	3.84	152	3.86
H	385	9.78	387	9.83
I	130	3.30	132	3.35
J	003	.076	004	0.10
K	135	3.43	137	3.48
L	105	2.67	107	2.72
M	085	2.16	86	2.18
N	065	1.65	66	1.68