

SKY81290: 1.2 A Single Flash LED Driver With AS²C Interface

Applications

- LED photo flash/torch devices
- Camera-enabled mobile devices
- Cellphones/smartphones
- Multimedia mobile phones

Features

- Input voltage range: 2.7 V to 5.5 V
- Single channel flash output
- Up to 1.2 A regulated output current
- Up to 88% efficiency
- Switching frequency: 2.0 MHz
- Separate flash enable
- Single resistor sets Flash and Movie Mode current
- Flash safety timer
- AS²Cwire single wire programming:
 - Movie Mode current
 - Flash/Movie Mode current ratio
 - Maximum flash current ratio
- True Load Disconnect
- Soft start and input current limit
- Over voltage (open LED, open circuit), short circuit, and over-temperature protection
- TDFN (14-pin, 3 x 3 mm and 3 x 2 mm) packages (MSL1, 260 °C per JEDEC J-STD-020)



Skyworks Green™ products are compliant with all applicable legislation and are halogen-free. For additional information, refer to *Skyworks Definition of Green™*, document number SQ04-0074.

Description

The SKY81290 is a high efficiency, 1.2 A high current boost converter with a programmable constant current sink. It is an ideal power solution for LED photo flash applications in all single cell, Li-ion powered products.

The SKY81290 maintains output current regulation by switching the internal high-side and low-side switch transistors. The transistor switches are pulse-width modulated at a fixed frequency of 2.0 MHz. The high switching frequency allows the use of a small external inductor and output capacitor, which makes the SKY81290 ideally suited for small battery-powered applications.

Skyworks proprietary Advanced Simple Serial Control (AS²Cwire™) digital interface is used to enable, disable, configure, and program the operation of the SKY81290. Using the AS²Cwire interface, the Movie Mode current level for each LED, flash safety timer, and the flash-to-Movie-Mode current ratio can be programmed to one of 16 levels.

The SKY81290 includes a separate flash enable input (FLEN) to initiate the flash operation. Also included is a flash inhibit pin (FLINH) that reduces the flash current to Movie Mode levels during high battery demand. The maximum Flash and Movie Mode current is set by one external resistor where the ratio of Flash to Movie Mode current is set at approximately 7:1.

The SKY81290 contains a thermal management system to protect the device in the event of an output short-circuit condition. Built-in circuitry prevents excessive inrush current during start-up. The shutdown feature reduces quiescent current to less than 1.0 μA.

The SKY81290 is available in a 14-pin, 3 x 3 mm TDFN package and a 14-pin, 3 x 2 mm TDFN package. A typical application circuit is shown in Figure 1. The pin configuration and packages are shown in Figure 2. Signal pin assignments and functional pin descriptions are provided in Table 1.

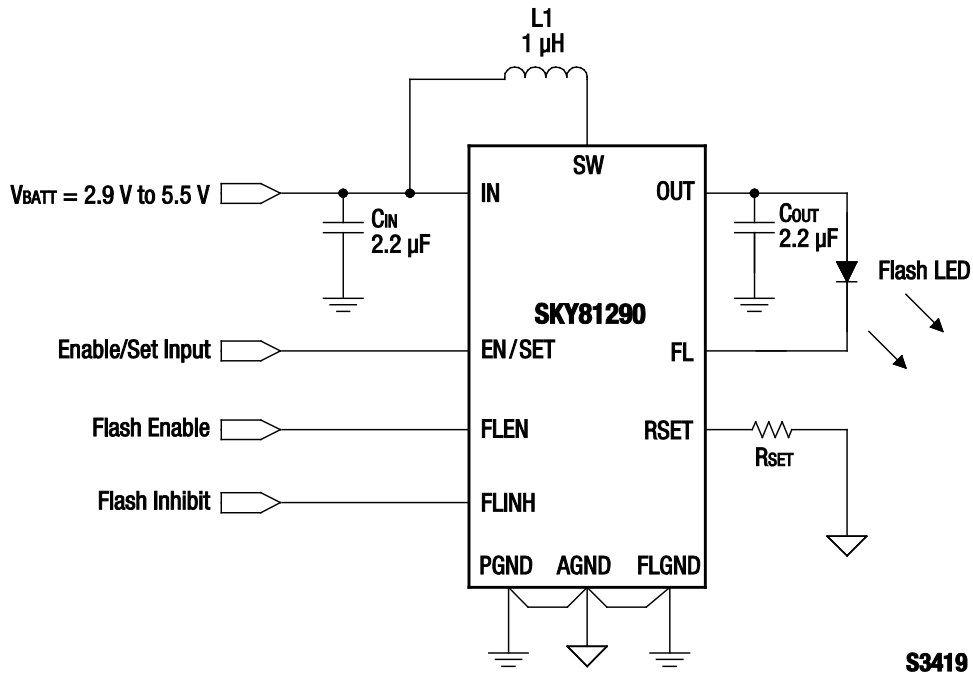

Figure 1. Typical Application Circuit

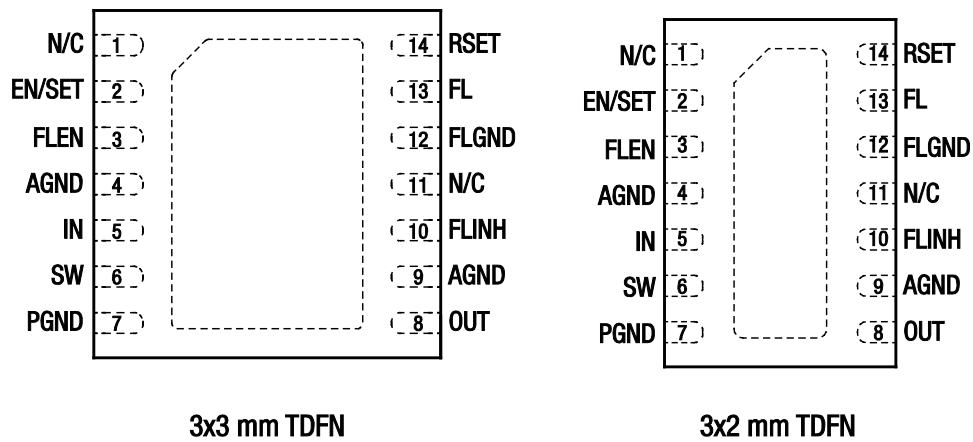

Figure 2. SKY81290 Pinout – 14-Pin TDFN Packages (Top View)

Table 1. SKY81290 Signal Descriptions

Pin #	Name	Description	Pin #	Name	Description
1	N/C	No connect.	8	OUT	Power output of the boost converter. Connect a 10 V, X7R 2.2 μ F or larger ceramic capacitor from OUT to PGND, and locate as close to the device as possible. Connect OUT to the anode of the flash LED.
2	EN/SET	Enable and serial control input. This pin is the AS ² Cwire addressing and programming input to adjust the Movie Mode current level, select the Flash-to-Movie-Mode ratio, and set the flash safety timer. This pin has an internal 675 k Ω pull-down resistor.	9	AGND	Analog ground pin. Connect AGND to PGND and FLGND at a single point as close to the device as possible.
3	FLEN	Flash enable pin. A low-to-high transition on this pin initiates a flash pulse and a high-to-low transition terminates a flash pulse. This pin has an internal 225 k Ω pull-down resistor.	10	FLINH	Flash inhibit pin. FLINH is an active high control input with an internal 225 k Ω resistor to AGND. A low-to-high transition on the FLINH pin reduces FL pin sink current to the maximum (default) Movie Mode current level.
4	AGND	Analog ground pin. Connect AGND to PGND and FLGND at a single point as close to the device as possible.	11	N/C	No connect.
5	IN	Flash output boost converter power input. Connect IN to the input power source. Connect a 10 V, X7R 2.2 μ F or larger ceramic capacitor from IN to PGND, and locate as close to the device as possible for optimum performance.	12	FLGND	Flash ground pin. Connect FLGND to PGND and AGND at a single point as close to the device as possible.
6	SW	Boost converter switching node. Connect a 1 μ H inductor between the SW and IN pins.	13	FL	LED flash current sink pin. Connect the cathode of the flash LED to this pin.
7	PGND	Power ground. Connect PGND to the same single point as AGND and located as close to the device as possible.	14	RSET	Flash current set pin. Connect a resistor from RSET to AGND to program the desired flash current for the current sink pin (FL).

Table 2. SKY81290 Absolute Maximum Ratings

Parameter	Symbol	Minimum	Maximum	Units
Maximum voltage rating	IN, OUT, SW	-0.3	+6.0	V
	EN/SET, FLEN, FLINH, RSET, FL	-0.3	VIN + 0.3	V
Storage temperature	T _S	-65	+150	°C
Junction operating temperature	T _J	-20	+150	°C
Soldering temperature (at leads, 10 sec)	T _{LEAD}		+300	°C
Thermal resistance (as mounted on an FR4 board, measured according to EIA/JESD 51 series):	Θ _{JA}	35		°C/W
		41		°C/W
Maximum power dissipation @ 25 °C:	P _D	3.29		W
		2.80		W

Note: Exposure to maximum rating conditions for extended periods may reduce device reliability. There is no damage to device with only one parameter set at the limit and all other parameters set at or below their nominal value. Exceeding any of the limits listed here may result in permanent damage to the device.

CAUTION: Although this device is designed to be as robust as possible, Electrostatic Discharge (ESD) can damage this device. This device must be protected at all times from ESD. Static charges may easily produce potentials of several kilovolts on the human body or equipment, which can discharge without detection. Industry-standard ESD precautions should be used at all times.

Table 3. SKY81290 Recommended Operating Conditions

Parameter	Symbol	Minimum	Typical	Maximum	Units
Input voltage	V _{IN}	2.7		5.5	V
Operating temperature	T _{OP}	-40		+85	°C

Electrical and Mechanical Specifications

The absolute maximum ratings of the SKY81290 are provided in Table 2. Recommended operating conditions are specified in Table 3. Electrical specifications are provided in Table 4.

Typical performance characteristics of the SKY81290 are illustrated in Figures 3 to 19.

Table 4. SKY81290 Electrical Specifications (Note 1)

($V_{IN} = 3.6\text{ V}$, $C_{IN} = C_{OUT} = 2.2\ \mu\text{F}$, $R_{SET} = 162\ \text{k}\Omega$, $L = 1\ \mu\text{H}$, $T_A = -40\ ^\circ\text{C}$ to $+85\ ^\circ\text{C}$ [Typical Values are $T_A = +25\ ^\circ\text{C}$], Unless Otherwise Noted)

Parameter	Symbol	Test Condition	Min	Typical	Max	Units
Power Supply, Current Sinks						
Input voltage range (Note 2)	V_{IN}		2.7		5.5	V
Supply current	$I_{IN(O)}$	EN/SET = FLEN = IN, FL load = 1 A		1.40		mA
		EN/SET = IN, FLEN = AGND		0.23		mA
Input shutdown current	I_{SHDN}	EN/SET and FLEN = AGND			1	μA
Maximum flash current	$I_{FL(MAX)}$	RSET = 135 k Ω , $V_F = 3.3\text{ V}$, $V_{IN} = 4.2\text{ V}$	1.2			A
Boost switch current limit	I_{LIMIT}		1.8		2.8	A
Flash current accuracy	$I_{FL(ACC)}$	$I_{FL} = 1\text{ A}$	-8		+8	%
Total output current, Movie Mode	$I_{MM(LOAD)}$	Movie Mode current set to 100%, $I_{FL} = 1\text{ A}$		143		mA
Movie Mode current accuracy	$I_{MM(ACC)}$		-8		+8	%
Flash to Movie Mode ratio	$I_{FL/IMM}$			7		-
Switching frequency	f_{OSC}	$T_A = 25\ ^\circ\text{C}$	1.5	2.0	2.5	MHz
Over-temperature shutdown threshold	T_{SD}			140		$^\circ\text{C}$
Output over-voltage limitation	V_{OVP}			5.3		V
Open LED, short circuit protection threshold	V_{FL_FLT}			150		mV
Protection delay time	t_{FLT_DEL}			1.4		ms
EN/SET, FLEN, FLINH						
Logic threshold:	V_{IL} V_{IH}		1.4		0.4	V
						V
Internal pull-down resistance (EN/SET)	R_{EN/SET_PUDN}			675		k Ω
Internal pull-down resistance (FLEN, FLINH)	R_{PUDN}			225		k Ω
Serial interface low time (EN/SET)	$t_{EN/SET(LO)}$		0.3		75	μs
Minimum EN/SET high time	$t_{EN/SET(HI-MIN)}$			50		ns
Maximum EN/SET high time	$t_{EN/SET(HI-MAX)}$				75	μs
EN/SET off timeout time	$t_{EN/SET(OFF)}$				500	μs
EN/SET latch timeout time	$t_{EN/SET(LAT)}$				500	μs
FLEN delay time:	$t_{FLEN(ON)}$ $t_{FLEN(OFF)}$	EN/SET = AGND		40		μs
				10		μs
FLINH on delay time	$t_{FLINH(ON)}$			93		μs
Auto Disable Function						
Shorted LED detection voltage	$V_{LED(DETECT)}$	$V_{IN} = 3.6\text{ V}$, $I_{LED} = 2.4\text{ mA}$	1.7			V

Note 1: Performance is guaranteed only under the conditions listed in this Table.

Note 2: Flash mode operation may be limited by the boost switch current limit.

Typical Performance Characteristics

($V_{IN} = 3.6\text{ V}$, $C_{IN} = C_{OUT} = 2.2\ \mu\text{F}$, $R_{SET} = 162\ \text{k}\Omega$, $L = 1\ \mu\text{H}$, $T_A = -40\text{ }^\circ\text{C}$ to $+85\text{ }^\circ\text{C}$ [Typical Values are $T_A = +25\text{ }^\circ\text{C}$], Unless Otherwise Noted)

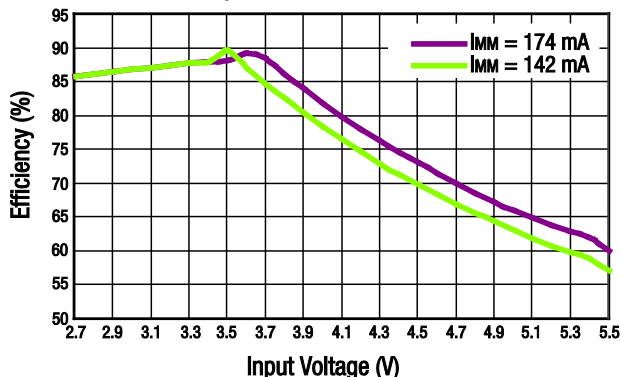

Figure 3. Movie Mode Efficiency vs Input Voltage

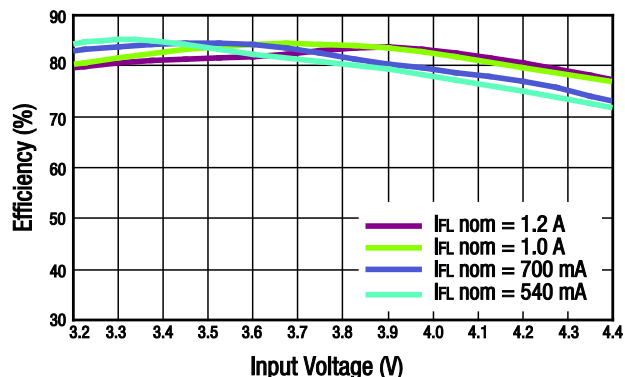

Figure 4. Flash Mode Efficiency vs Input Voltage

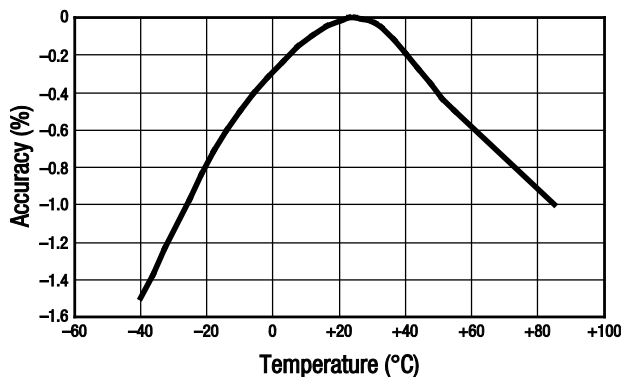

Figure 5. Flash Mode Current Accuracy vs Temperature ($I_{FL} = 1\ \text{A}$, $V_{IN} = 3.6\ \text{V}$, $L = 1\ \mu\text{H}$)

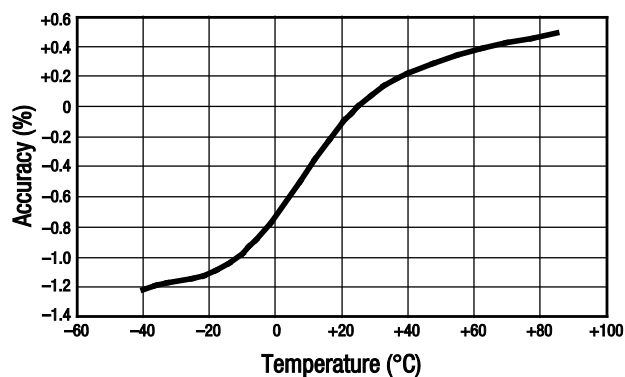

Figure 6. Movie Mode Current Accuracy vs Temperature ($I_{MM} = 142\ \text{mA}$, $V_{IN} = 3.6\ \text{V}$, $L = 1\ \mu\text{H}$)

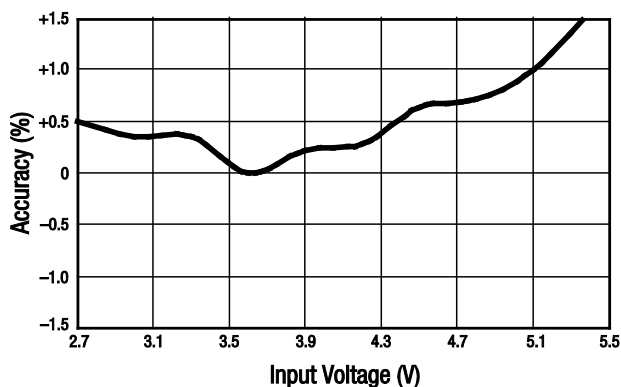

Figure 7. Movie Mode Current Accuracy vs Input Voltage ($I_{MM} = 142\ \text{mA}$, $L = 1\ \mu\text{H}$)

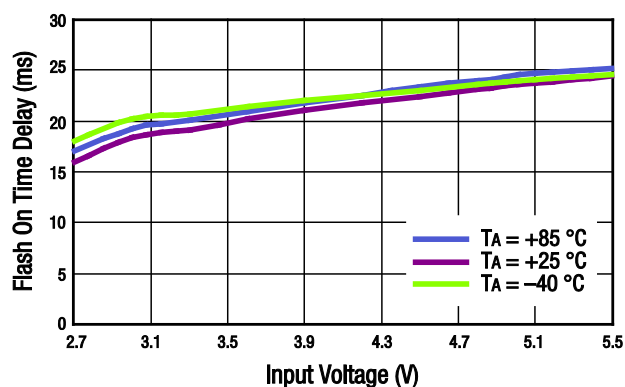

Figure 8. Flash On Time Delay vs Input Voltage

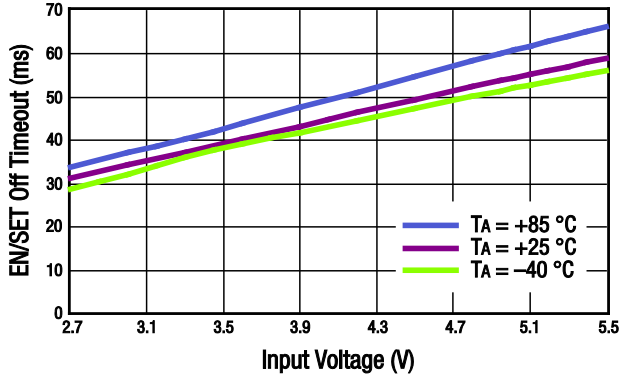

Figure 9. EN/SET Off Timeout vs Input Voltage

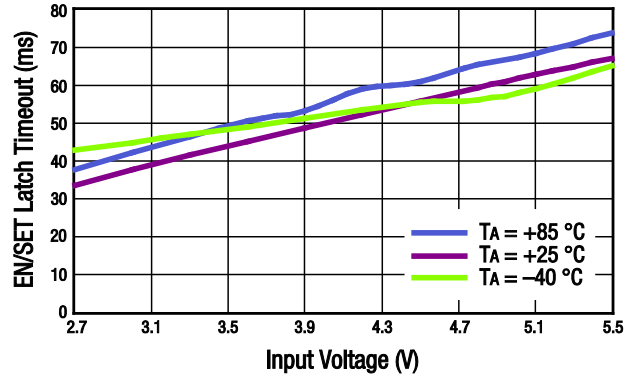

Figure 10. EN/SET Latch Timeout vs Input Voltage

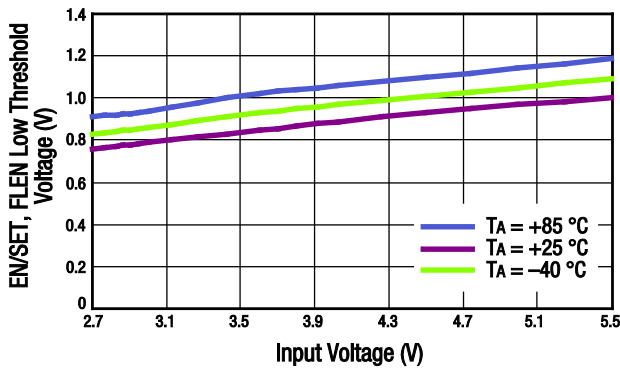

Figure 11. EN/SET, FLEN Low Threshold Voltage vs Input Voltage

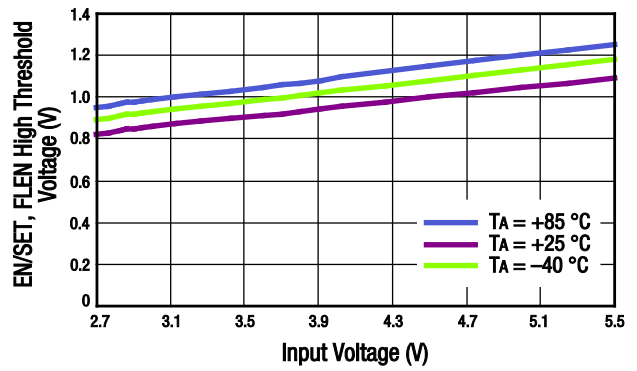

Figure 12. EN/SET, FLEN High Threshold Voltage vs Input Voltage

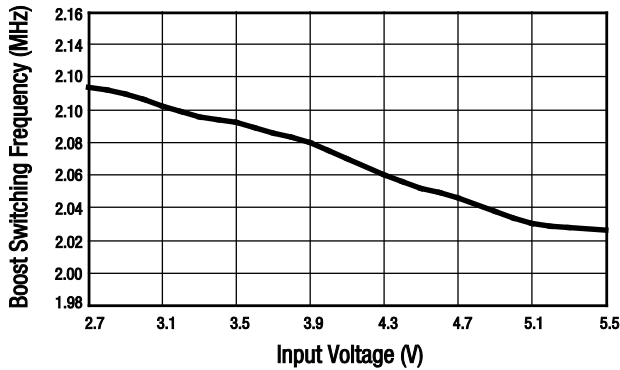

Figure 13. Boost Switching Frequency vs Input Voltage
(TA = 25 °C, L = 1 μH)

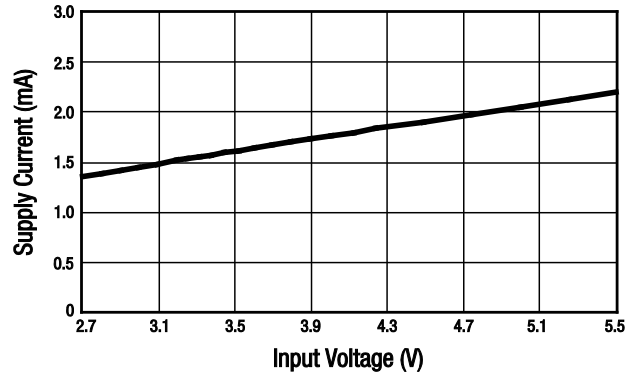

Figure 14. Supply Current vs Input Voltage
(VEN/SET = VFLEN = VIN, IFL = 0 mA, Non-Switching)

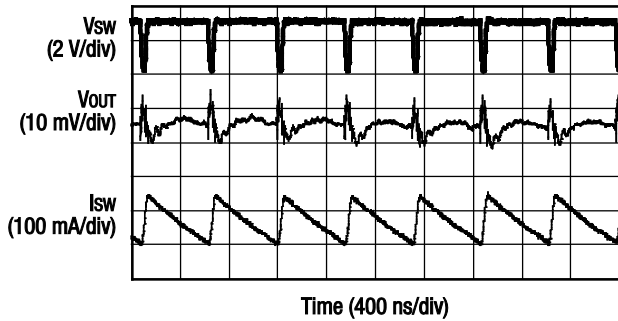

Figure 15. Movie Mode Ripple
 (IMM = 142 mA, COUT = 2.2 μF, VIN = 3.6 V, L = 1 μH)

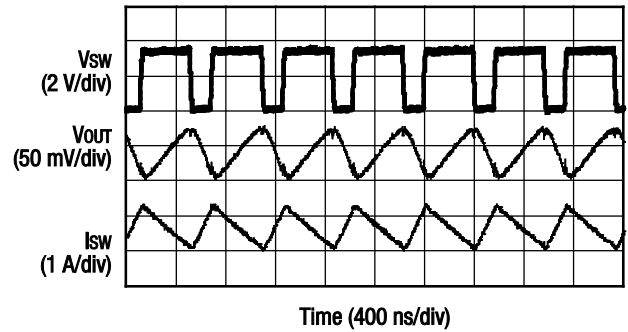

Figure 16. Flash Mode Ripple
 (IFL = 1 A, COUT = 2.2 μF, VIN = 3.6 V, L = 1 μH)

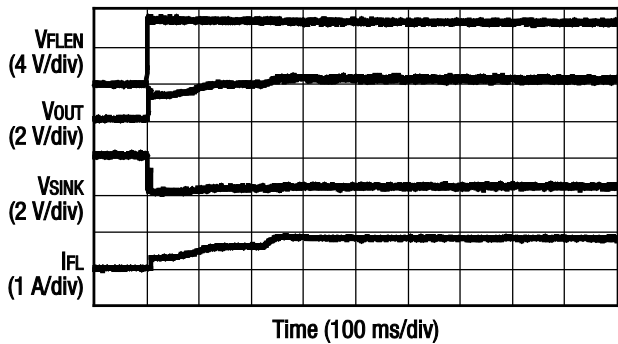

Figure 17. Flash Turn On
 (Vout = 3.6 V, IFL = 1 A)

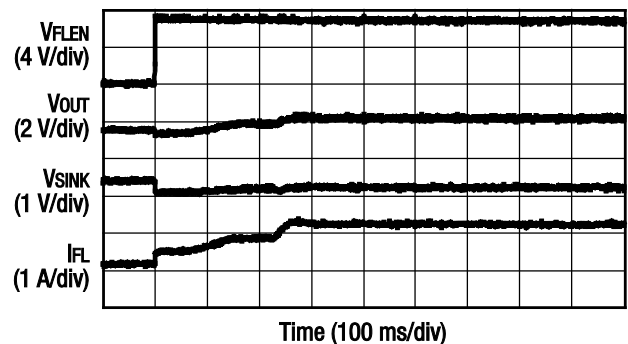

Figure 18. Movie Mode to Flash Turn On
 (Vout = 3.6 V, IFL = 174 mA to 1.2 A)

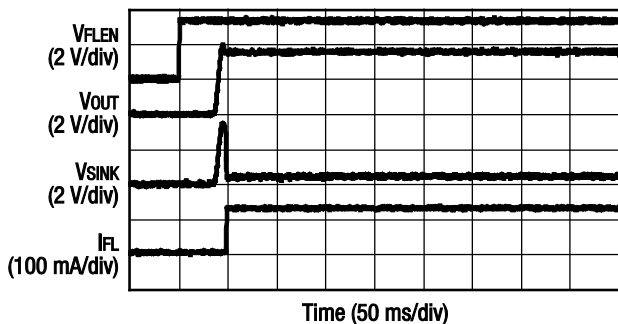

Figure 19. Movie Mode Turn On
 (Vout = 3.6 V, IFL = 142 mA)

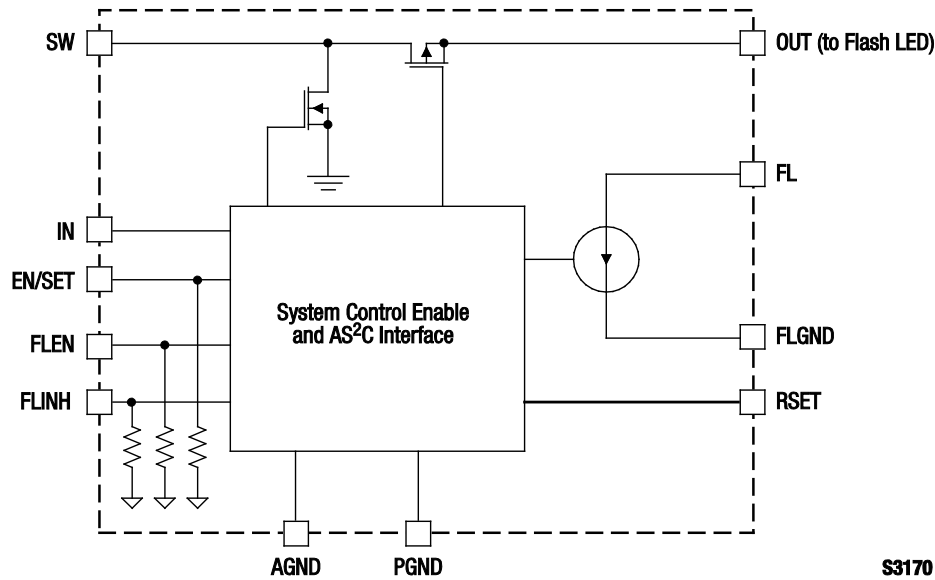

Figure 20. SKY81290 Functional Block Diagram

S3170

Functional Description

The SKY81290 is a boost converter with a current-regulated output designed to drive high current, white LEDs used in camera flash applications. The SKY81290 has a constant current sink channel to accurately regulate the current flow through a high current, high intensity white flash LED.

The SKY81290 has two basic operating modes: a Flash Mode controlled by the FLEN pin, and a Movie/Torch Mode controlled through the AS²Cwire interface.

A functional block diagram is shown in Figure 20.

Flash Mode

A flash pulse is initiated by strobing the FLEN input pin low-to-high. The maximum flash current in the SKY81290 is set by an external resistor (R_{SET}) that sets the flash current and the maximum Movie Mode current. The maximum flash current is limited by the boost switch current limit.

For mobile GSM systems where the phone remains in constant contact with the base station by regular communication, a FLINH pin is provided to prevent both the camera flash and PA transmission pulses from occurring simultaneously. This avoids potential dips to the Li-ion battery voltage below the system's cut off voltage.

During a flash event, strobing the FLINH pin low-to-high reduces the LED current to the default Movie Mode current level for the duration of FLINH. Strobing FLINH high-to-low instructs the SKY81290 to revert the flash LED current to its maximum level, assuming that the FLEN pin is still active (high).

Move (Torch) Mode

The Movie (Torch) Mode current level is programmed by the SKY81290 AS²Cwire interface using the EN/SET pin. The Movie Mode current level can be adjusted to one of 16 steps using a logarithmic scale where each code level is 1 dB below the previous code. The maximum Movie Mode current is fixed at 1/7th of the maximum programmed flash current set by the R_{SET} resistor. The manual FLEN signal has priority over Movie Mode operation.

The FLEN signal overrides the Movie Mode operation when toggled to a logic high level. The SKY81290 does not reenter Movie Mode when FLEN is brought low. To reenter Movie Mode after a flash event, the device must be cycled off and back on to reset the Movie Mode and reprogrammed with the AS²Cwire interface to the desired Movie Mode operation.

Open LED or Short Circuit Protection

The SKY81290 features open LED protection and short circuit protection. When the FL pin voltage drops below 150 mV, the boost output reaches the overprotection level (typically 5.3 V).

After the output voltage reaches the overprotection level, if the FL voltage is kept below 150 mV for more than 1.4 msec (typical), the SKY81290 triggers the open LED/short circuit protection and latches off the device. The output is also disconnected from the input supply. To restart the device requires cycling the input power or EN pin.

Flash Safety Timer

The SKY81290 is equipped with a flash safety timer that will turn off the flash according to the programmed safety time in Flash Mode. The default safety time is set as 1 sec but can be programmed between 0.25 sec and 1.75 sec. The safety timer can also be disabled through AS²Cwire programming.

Short LED Protection

The SKY81290 is equipped with an auto-disable feature for the flash LED channel. After the device is enabled and system start up commences, a test current of 2.4 mA (typical) is forced through the sink channel. The channel is disabled if the voltage of the FL pin does not drop to a predetermined threshold (1.7 V minimum).

This feature is very convenient for disabling the current sink when the flash LED fails to a short circuit. This small test current is added to the set output current in both Flash and Movie Mode conditions.

Over-Temperature Protection

The SKY1290 has internal thermal protection circuitry to latch off the device if the internal power dissipation exceeds a preset thermal limit for over 1.4 ms. The junction over-temperature threshold is 140 °C. During Flash or Movie Mode operation, if an environmental condition, flash current sink, or the boost converter causes the internal die temperature to rise above 140 °C, the device latches off and disconnects the output from the input circuit.

Flash Mode LED Current

Flash sink current can be programmed up to a maximum of 1.2 A. The maximum flash current is set by the R_{SET} resistor. For the desired flash current, the resistor value can be calculated using the following equation:

$$I_{FL} = \frac{162\text{ k}\Omega \times A}{R_{SET}} = \frac{162\text{ k}\Omega}{135\text{ k}\Omega} = 1.2\text{ A}$$

A flash event is initiated by asserting the FLEN pin. A flash event is automatically terminated when FLEN is de-asserted or the flash safety timer expires. Whenever the FLINH pin is asserted, the

default Movie Mode current level appears at the FL channel. The default Movie Mode current level is maintained on FL as long as the FLINH and FLEN pins are asserted.

Besides setting the flash current using the R_{SET} resistor, the flash current can be changed after FLEN is asserted by programming the Movie Mode current register.

AS²Cwire Control of Movie Mode Operation

Movie Mode operation is managed by programming the AS²Cwire interface. This interface relies on the number of rising edges of the EN/SET pin to address and load internal data registers as indicated in Table 5.

Register 0 controls the Movie Mode current level as a percentage of the maximum Movie Mode current. Table 5 also shows the default values for each of the address registers.

AS²Cwire Serial Interface

The AS²Cwire interface latches data or an address after the EN/SET pin has been held high for longer than t_{LAT} (500 μs). Address or data are differentiated by the number of EN/SET rising edges. Since the data registers are 4 bits each, the differentiating number of pulses is 2⁴ or 16, so that Register/address 0 is signified by 17 rising edges and Register/address 3 by 20 rising edges (refer to Table 5).

Data in Register/address 0 is inclusively applied to any number of rising edges between 1 and 16. A typical write protocol is a burst of EN/SET rising edges that signify a particular address followed by a pause with EN/SET held high for the prescribed t_{LAT} timeout period, then a burst of rising edges signifying data, and a t_{LAT} timeout for the data registers.

Once an address is set, then multiple writes to the corresponding data register are allowed. Address 0 is the default address on the first rising edge after the SKY81290 has been disabled.

Table 5. AS²Cwire Serial Interface Addressing

Register/Address	EN/SET Rising Edges	Function	Default (No Programming)
0	17	Movie Mode current	100%
1	18	Flash safety timer time	1 second
2	19	Output enable control	On
3	20	Flash current ratio (Flash/Movie Mode current ratio is fixed at 1:7)	100%

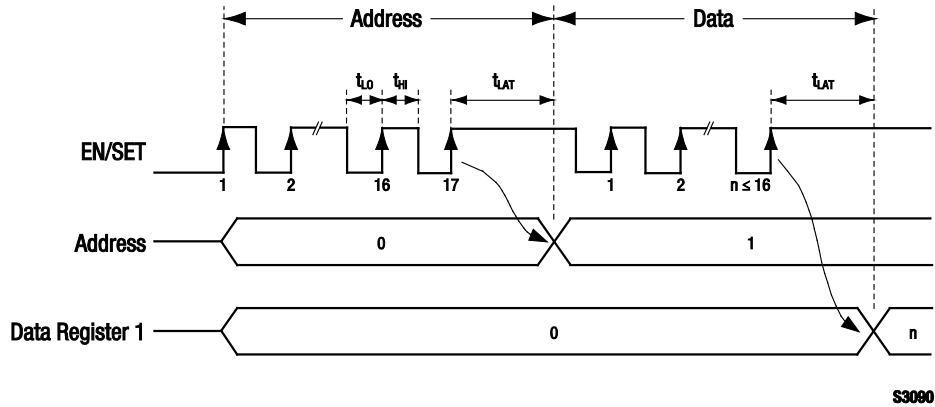

Figure 21. AS²Cwire Serial Interface Timing Diagram

When EN/SET is transitioned from high to low and held low longer than t_{OFF} (500 μ s), the device enters a shutdown mode and draws less than 1 μ A from the input supply. All data and addresses are cleared (reset to 0) during shutdown.

AS²Cwire addressing controls the Movie Mode output current and the ratio of Movie Mode current to flash current. If there are no programmed write instructions applied to the EN/SET pin before the assertion of the FLEN pin, and the device is enabled, then all registers are loaded with the default values shown in Table 5.

If the number of rising edges applied at the EN/SET pin is fewer than 17, the internal state machine interprets the instruction to program the output currents to the desired current level for Movie Mode operation.

A timing diagram for the AS²Cwire interface is shown in Figure 21.

Register 0: Movie Mode Current

The SKY81290 Movie Mode current settings are controlled using the AS²Cwire interface. The ratio between the flash current level and maximum Movie Mode current level is fixed at 1:7. For example, if an R_{SET} value of 135 k Ω is chosen, then the flash current is set to 1200 mA. For Movie Mode operation, the maximum current available is then:

$$I_{FL(MAX)} = 162 \text{ k}\Omega / R_{SET} \times 1000 \text{ mA}$$

$$I_{MOVIEMODE} = I_{FL(MAX)} / 7 = 1200 \text{ mA} / 7 = 171 \text{ mA}$$

Register/address 0 controls precise Movie Mode current levels. The Movie Mode current can be adjusted in a logarithmic fashion to one of 16 steps represented as a fraction of the maximum Movie Mode current as noted in Table 6.

Table 6. Register/Address 0: Movie Mode Current Programming

Data	Percentage of Maximum Movie Mode Current	Data	Percentage of Maximum Movie Mode Current
1 (default)	100.0	9	49.5
2	93.7	10	43.2
3	87.4	11	36.9
4	81.1	12	30.6
5	74.8	13	24.3
6	68.4	14	18.0
7	62.1	15	11.7
8	55.8	16	5.5

Table 7. Register/Address 1: Flash Safety Timer

Data	Flash Safety Timer Time (seconds)	Data	Flash Safety Timer Time (seconds)
1	Disables the timer	5 (default)	1.00
2	0.25	6	1.25
3	0.50	7	1.50
4	0.75	8	1.75

Table 8. Register/Address 2: Movie Mode Enable Control

Data	Movie Mode Enable	Data	Movie Mode Enable
1	Off	3	On
2	Off	4 (default)	On

Table 9. Register/Address 3: Flash Current Ratio

Data	Maximum Flash Current Ratio	Data	Maximum Flash Current Ratio
1 (default)	100%	3	70%
2	84%	4	62%

Register 1: Flash Safety Timer

The SKY81290 is equipped with a flash safety timer. This timer limits the operation time in Flash Mode to thermal issues. The safety timer can be adjusted from 0.25 seconds to 1.75 seconds as noted in Table 7.

Register 2: Movie Mode Enable Control

To enable or disable Movie Mode, a write instruction to address 2 is applied to the EN/SET pin (see Table 8). If no write instruction is applied, the default value for address 2 is “on.” During a flash event, the LED is enabled regardless of the Movie Mode setting.

Register 3: Flash Current Ratio

During flash start up, the maximum peaked sustained flash current level is programmable using Register/address 3. This level is a fraction of the maximum flash current set by R_{SET}. The ratio can vary from 100 percent to 62 percent in 4 steps as shown in Table 9.

Shutdown

Since the flash current sink is the only power return for the flash LED load, there is no leakage current to load if all the sink switches are disabled. When the EN/SET pin is held low for greater than t_{OFF} (500 μs), the SKY81290 flash boost converter

section enters shutdown mode and draws less than 1 μA from the input power source. All data and address registers for the Flash and/or Movie Mode are cleared (reset to 0) during shutdown.

Evaluation Board Description

The SKY81290 Evaluation Board is used to test the performance of the SKY81290 LED Driver. An Evaluation Board schematic diagram is provided in Figure 22. Layer details for the Evaluation Board are shown in Figure 23. Table 10 provides the Bill of Materials (BOM) for Evaluation Board components.

Package Dimensions

The PCB layout footprint for the SKY81290 is provided in Figure 24 (3 x 3 TDFN) and Figure 25 (3 x 2 TDFN). Typical case markings are shown in Figure 26.

Package dimensions, and tape and reel dimensions for the 14-pin, 3 x 3 mm TDFN package are shown in Figures 27 and 28, respectively. Package dimensions, and tape and reel dimensions for the 14-pin, 3 x 2 mm TDFN package are shown in Figures 29 and 30, respectively.

Package and Handling Information

Instructions on the shipping container label regarding exposure to moisture after the container seal is broken must be followed. Otherwise, problems related to moisture absorption may occur when the part is subjected to high temperature during solder assembly.

The SKY81290 is rated to Moisture Sensitivity Level 1 (MSL1) at 260 °C. It can be used for lead or lead-free soldering. For

additional information, refer to the Skyworks Application Note, *Solder Reflow Information*, document number 200164.

Care must be taken when attaching this product, whether it is done manually or in a production solder reflow environment. Production quantities of this product are shipped in a standard tape and reel format.

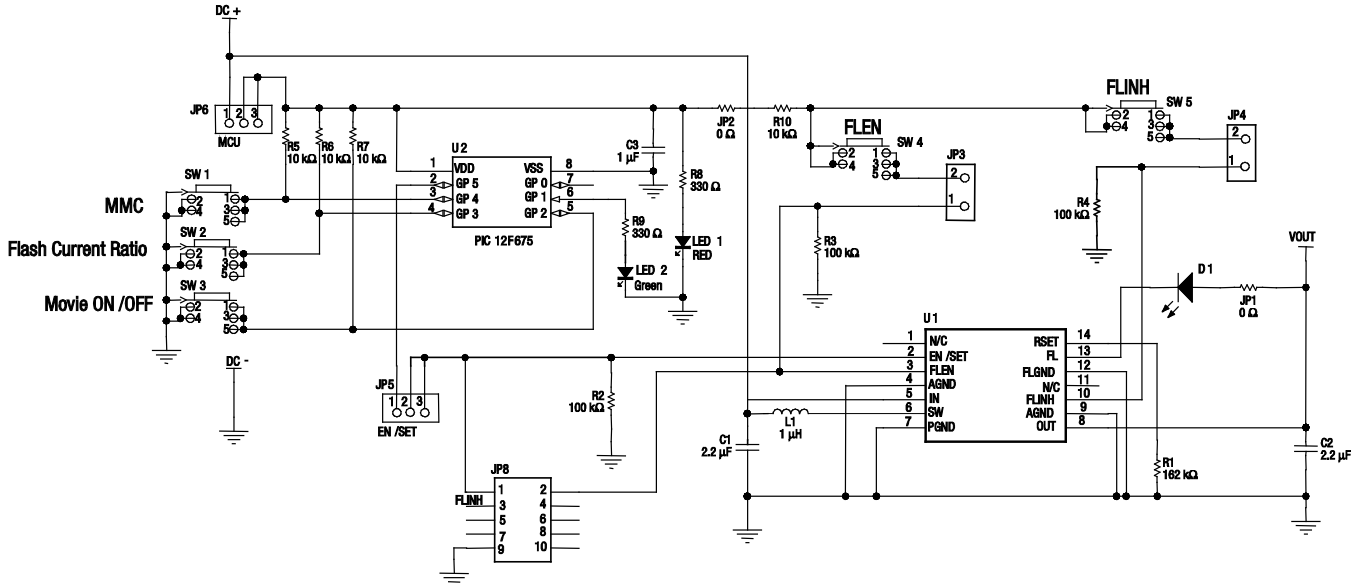

S3265

Figure 22. SKY81290 Evaluation Board Schematic

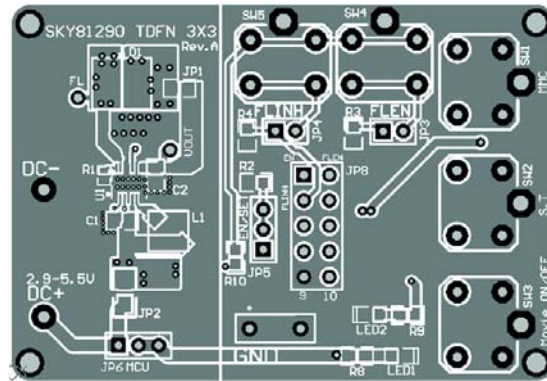

Top Layer

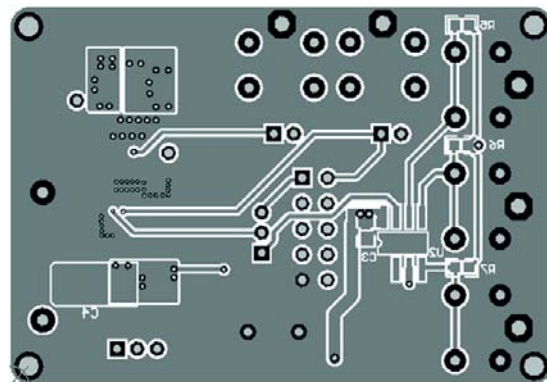

Bottom Layer

Figure 23. SKY81290 Evaluation Board Layer Details

Table 10. SKY81290 Evaluation Board Bill of Materials (BOM)

Component	Description	Manufacturer	Part #
C1, C2	2.2 μ F, 10 V, X7R, 0603	Murata	GRM188R71A225KE15
C3	1 μ F, 10 V, X5R, 0805	Murata	GRM216R61A105KA01
D1	White flash LED	Seoul Semiconductor	SSC-FCW401Z4
JP3, JP4, JP5, JP6	Connecting header, 2mm zip	Sullins Electronics	PRPN401PAEN
L1	1 μ H, 3 A, 45 m Ω , 2.5 mm x 2 mm	TOKO	DFE252012C
LED1	Red LED, 1206	Chicago Miniature Lighting	CMD15-21SRC/TR8
LED2	Green LED, 1206	Chicago Miniature Lighting	CMD15-21VGC/TR8
JP1, JP2	0 Ω , 1%	Vishay	Chip resistor
R1	162 k Ω , 1%, 0402	Vishay	Chip resistor
R2, R3, R4	100 k Ω , 1%, 0603	Vishay	Chip resistor
R5, R6, R7, R10	10 k Ω , 1%, 0603	Vishay	Chip resistor
R8, R9	330 Ω , 1%, 0603	Vishay	Chip resistor
SW1 to SW5	Switches, SPST, 5 mm	ITT Industries	PTS645TL50
U1	1.2 A step-up current regulator for flash LEDs	Skyworks	SKY81290
U2	8-bit CMOS, flash-based I/C (8-pin PDIP package)	Microchip	PIC12F675

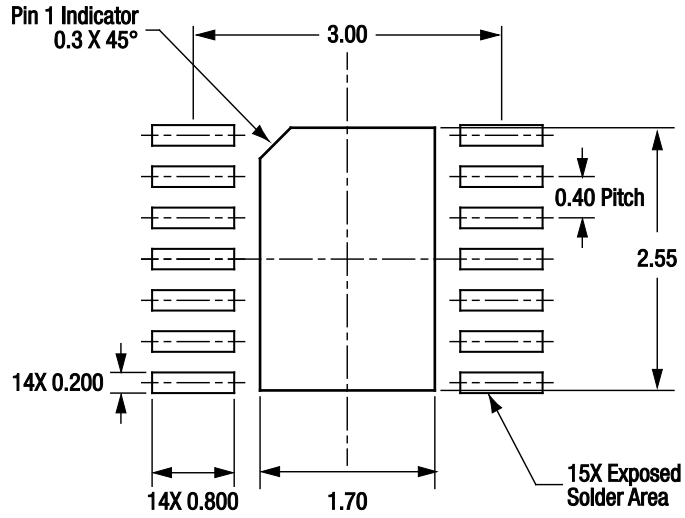

All dimensions are in millimeters

S3417

Figure 24. SKY81290 PCB Layout Footprint (3 x 3 TDFN)

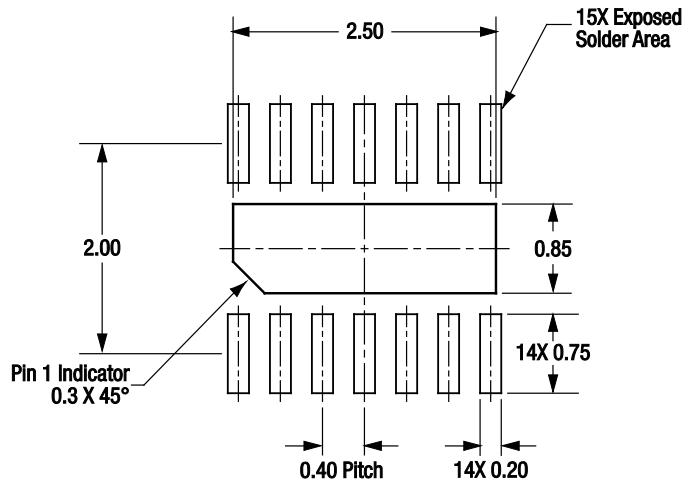

All dimensions are in millimeters

S3418

Figure 25. SKY81290 PCB Layout Footprint (3 x 2 TDFN)

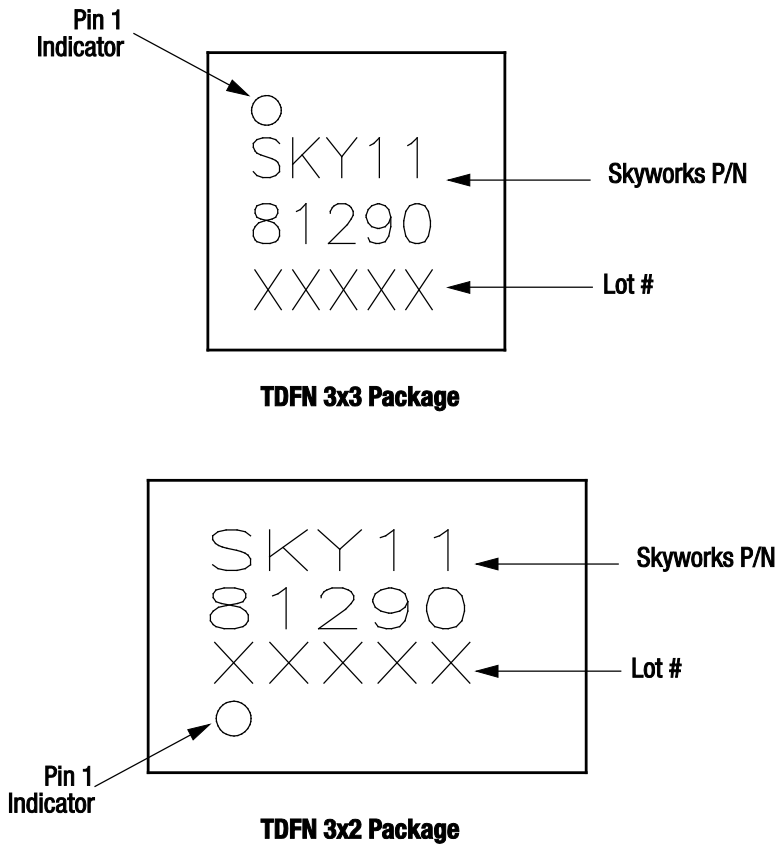
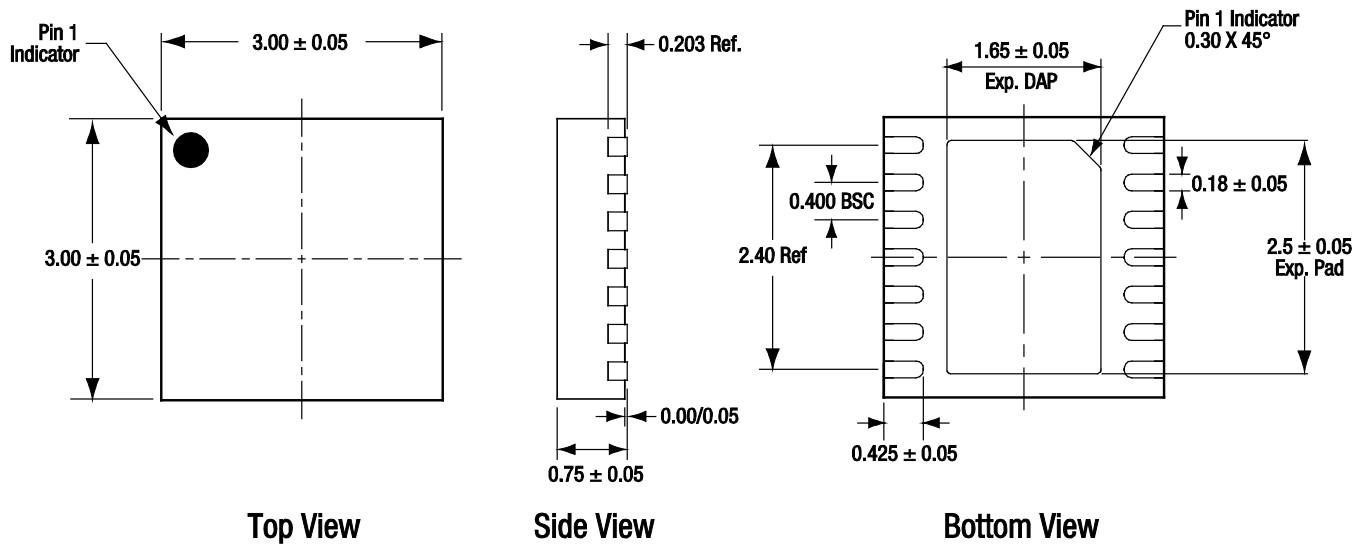

Figure 26. Typical Case Markings (Top View)



All measurements are in millimeters.

S3266

Figure 27. SKY81290 14-Pin TDFN Package Dimensions (3 x 3 mm)

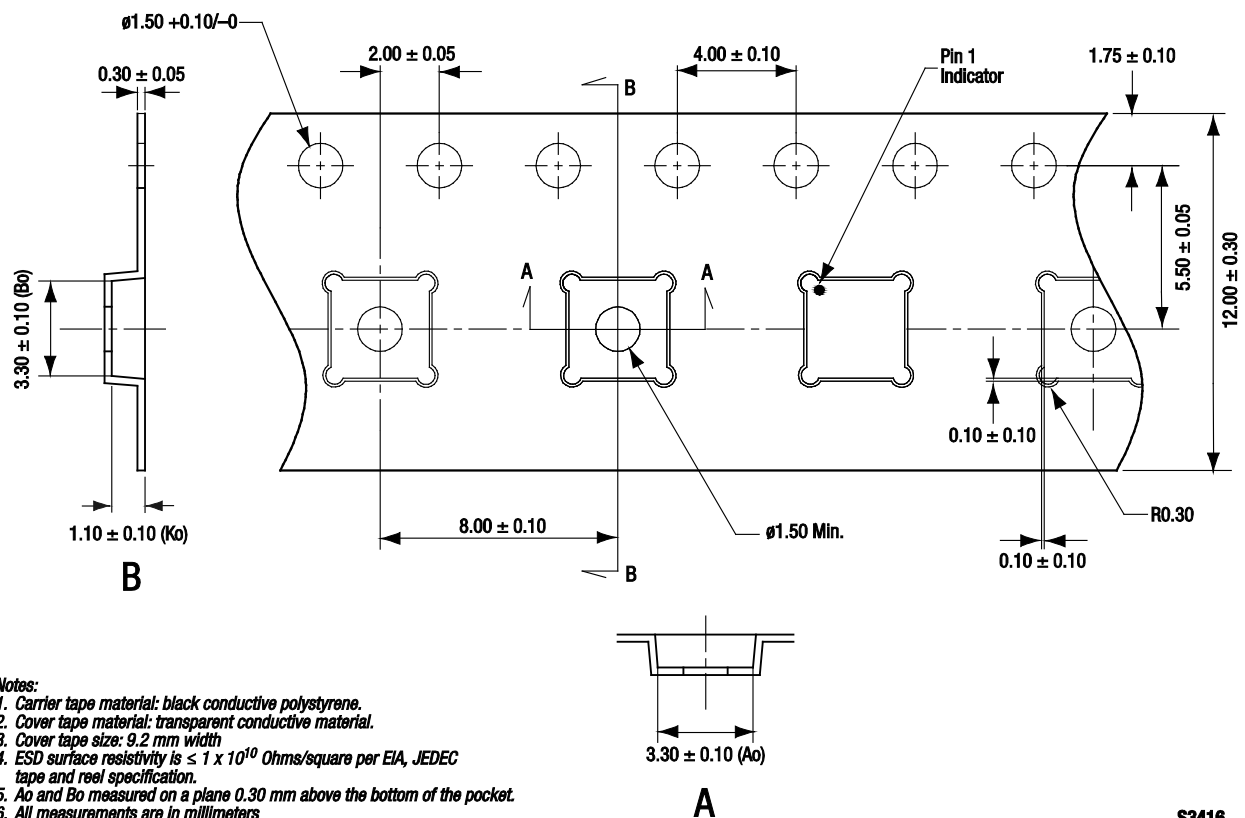

S3416

Figure 28. SKY81290 Tape and Reel Dimensions (3 x 3 mm Package)

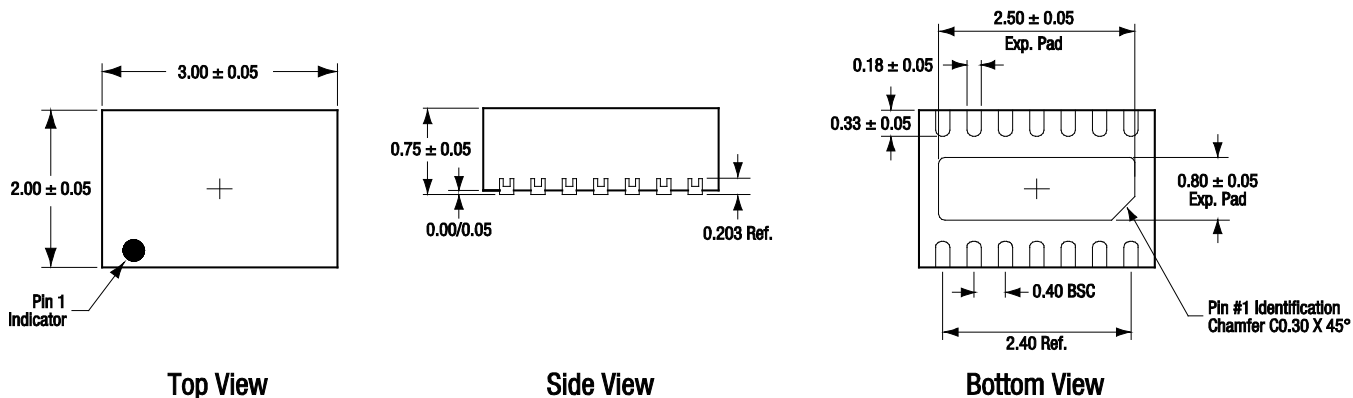

All measurements are in millimeters.

S3268

Figure 29. SKY81290 14-Pin TDFN Package Dimensions (3 x 2 mm)

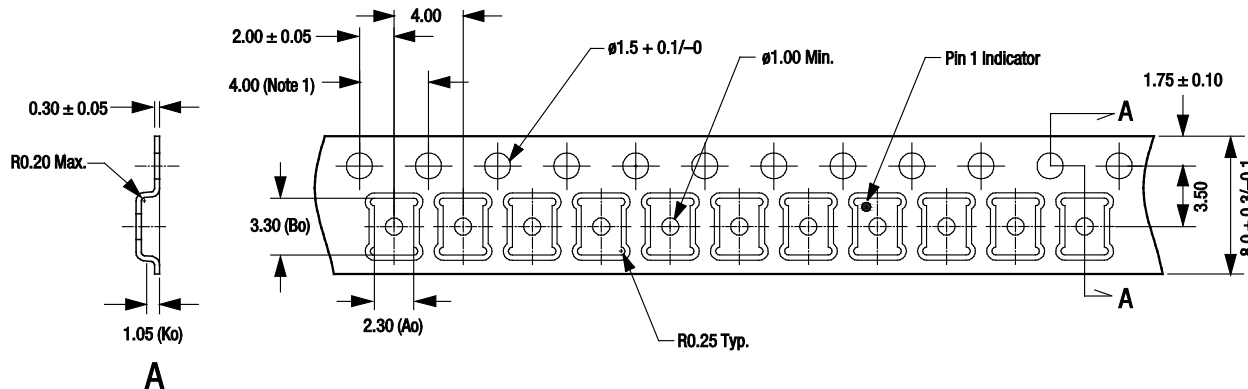

Notes:

1. Sprocket hole pitch cumulative tolerance ± 0.2 .
2. Carrier tape material: black conductive polystyrene.
3. Pocket position relative to sprocket hole measured as true position of pocket, not pocket hole.
4. Cover tape material: transparent conductive material.
5. All measurements are in millimeters.

S3415

Figure 30. SKY81290 Tape and Reel Dimensions (3 x 2 mm Package)

Ordering Information

Model Name	Manufacturing Part Number	Evaluation Board Part Number
SKY81290 Single Flash LED Driver	TDFN, 3 x 3 mm: SKY81290-11-564LF	SKY81290-11-564LF-EVB1
	TDFN, 3 x 2 mm: SKY81290-11-563LF	SKY81290-11-563LF-EVB2

Copyright © 2012, 2013 Skyworks Solutions, Inc. All Rights Reserved.

Information in this document is provided in connection with Skyworks Solutions, Inc. ("Skyworks") products or services. These materials, including the information contained herein, are provided by Skyworks as a service to its customers and may be used for informational purposes only by the customer. Skyworks assumes no responsibility for errors or omissions in these materials or the information contained herein. Skyworks may change its documentation, products, services, specifications or product descriptions at any time, without notice. Skyworks makes no commitment to update the materials or information and shall have no responsibility whatsoever for conflicts, incompatibilities, or other difficulties arising from any future changes.

No license, whether express, implied, by estoppel or otherwise, is granted to any intellectual property rights by this document. Skyworks assumes no liability for any materials, products or information provided hereunder, including the sale, distribution, reproduction or use of Skyworks products, information or materials, except as may be provided in Skyworks Terms and Conditions of Sale.

THE MATERIALS, PRODUCTS AND INFORMATION ARE PROVIDED "AS IS" WITHOUT WARRANTY OF ANY KIND, WHETHER EXPRESS, IMPLIED, STATUTORY, OR OTHERWISE, INCLUDING FITNESS FOR A PARTICULAR PURPOSE OR USE, MERCHANTABILITY, PERFORMANCE, QUALITY OR NON-INFRINGEMENT OF ANY INTELLECTUAL PROPERTY RIGHT; ALL SUCH WARRANTIES ARE HEREBY EXPRESSLY DISCLAIMED. SKYWORKS DOES NOT WARRANT THE ACCURACY OR COMPLETENESS OF THE INFORMATION, TEXT, GRAPHICS OR OTHER ITEMS CONTAINED WITHIN THESE MATERIALS. SKYWORKS SHALL NOT BE LIABLE FOR ANY DAMAGES, INCLUDING BUT NOT LIMITED TO ANY SPECIAL, INDIRECT, INCIDENTAL, STATUTORY, OR CONSEQUENTIAL DAMAGES, INCLUDING WITHOUT LIMITATION, LOST REVENUES OR LOST PROFITS THAT MAY RESULT FROM THE USE OF THE MATERIALS OR INFORMATION, WHETHER OR NOT THE RECIPIENT OF MATERIALS HAS BEEN ADVISED OF THE POSSIBILITY OF SUCH DAMAGE.

Skyworks products are not intended for use in medical, lifesaving or life-sustaining applications, or other equipment in which the failure of the Skyworks products could lead to personal injury, death, physical or environmental damage. Skyworks customers using or selling Skyworks products for use in such applications do so at their own risk and agree to fully indemnify Skyworks for any damages resulting from such improper use or sale.

Customers are responsible for their products and applications using Skyworks products, which may deviate from published specifications as a result of design defects, errors, or operation of products outside of published parameters or design specifications. Customers should include design and operating safeguards to minimize these and other risks. Skyworks assumes no liability for applications assistance, customer product design, or damage to any equipment resulting from the use of Skyworks products outside of stated published specifications or parameters.

Skyworks, the Skyworks symbol, and "Breakthrough Simplicity" are trademarks or registered trademarks of Skyworks Solutions, Inc., in the United States and other countries. Third-party brands and names are for identification purposes only, and are the property of their respective owners. Additional information, including relevant terms and conditions, posted at www.skyworksinc.com, are incorporated by reference.