

10Wrms DVB-T/20W ps UHF Amplifier

AU20-DHG is a full LD-MOS Broadcast Power Amplifier designed for both digital and analog applications. The unit is the state of the art in terms of easy assembly, reliability and performances. The complete unit can assure the compliance to all relevant international standards.

- Full LD-MOS Power Amplifier
- 20Wps Out
- 10Wrms Out DVB-T
- DTV (8 VSB): 20Wrms
- BroadBand (470-862 MHz)
- Designed for SKD sales
- Internal cabling free
- Easy maintenance without special tools
- RS232-RS485 interface
- Control software included
- Extremely strong mechanical structure



This picture is a mere example, it does not bind the provided product

Electrical Data

Voltage Supply	88 to 240Vac
Power Consumption	180W @20W Ps Black Field @650MHz (typ.) 180W @10Wrms DVB-T @650MHz (typ.)
Current Consumption	1 A max @ 220 V digital application
Operating Temperature	0 to +45 °C
Humidity	Up to 90% (non condensing)
Gain Stability	0 to 45 deg. +/-0.5dB ¹
Gain	61dB nom. ±2dB (fine ADJ available)
Power Out (@1dB compression)	Min. 50W (Typ. 70W)
Input Return Loss	Min. -16dB (Typ. -20dB)
Output Return Loss	Min. -16dB (Typ. -20dB)
Load Mismatch (CW 30W F₀ 860MHz VSWR=2:1)	No degradation
P_{out} Common Amplif.	20W Ps IMD < -47dB Red Field (without precorrection)
P_{out} DVB-T	10Wrms shoulder < -36dBc (with precorrection)
DTV (8 VSB)	20Wrms
P_{out} PEP	50W IMD < -27 dBc

Mechanical data and Interfaces

Dimensions	19" 3HU std 400mm depth ²
Weight	12 Kg.
RF in	N connector rear panel
RF out	N connector rear panel
RF mon	SMA connector rear panel
RS232	D 9 poles front and rear panel
RS485	D 9 poles rear panel
Local Enable	Switch front panel Two-pole connector rear panel

¹ WARM UP:

To achieve the stability vs temperature correct value when the equipment is cold, please wait 30 minutes at least after switching on.

² See pag. 4

Contact Res-Ingenium, +39 0763 316333 Fax +39 0763316002- or visit www.res-ingenium.com for a complete listing.

Block Diagram

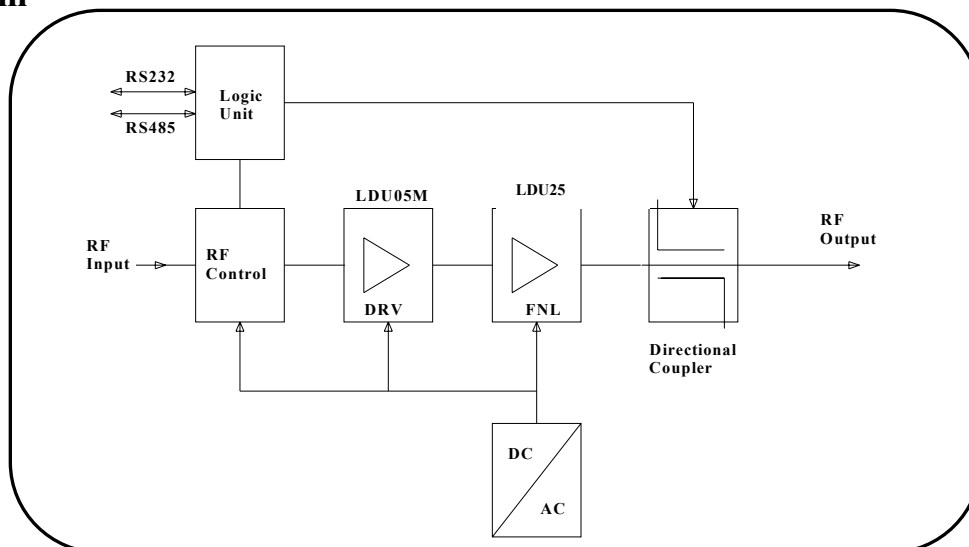

Remote control

Enable ³	RF Enable ON/Stand By
GAIN (option)	Gain setting

Readable data by remote computer or Control Logic Unit (through RS232/RS485)

STATUS/ALARMS	NOTES
Enable	ON/STAND BY
RF Faults	ACTIVE if Gain < 6dB referred to nominal
°C max	ACTIVE when RF Thermal Protection is ON
Pin max	ACTIVE when RF Overdrive Protection is ON
VSWR max	ACTIVE if VSWR max Protection is ON
I max	ACTIVE when Current is too high
MEASUREMENTS	
RF in	Input Power in mW (PS for analog, RMS for DVBT)
RF out	Output Power in W (PS for analog, RMS for DVBT)
RF DRV	RF Driver Output in W (PS for analog, RMS for DVBT)
RF Heatsink Temperature	Temperature in °C
IDC Driver	Value in A
IDC Final Stage	Value in A
VDC	PS Output Voltage

Self Protections

RF Thermal Protection	
Overdrive	Pin max must be set on the working channel with the used DVB-T or Analog signal
VSWR max	VSWR max must be set on the working channel with the used DVB-T or Analog signal
I max	

³ An output on the rear panel can manage the external Power Supply ON/OFF. The external PS will be switched OFF in case of alarm.

Contact Res-Ingenium, +39 0763 316333 Fax +39 0763316002- or visit www.res-ingenium.com for a complete listing.

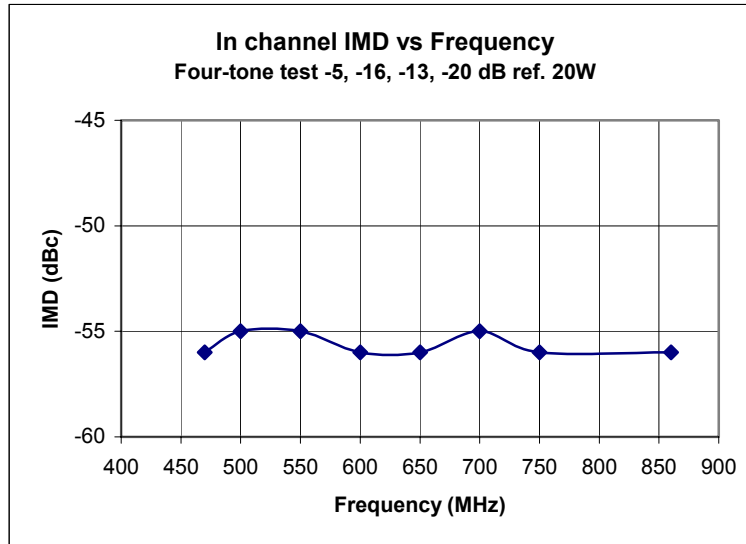

Without precorrection

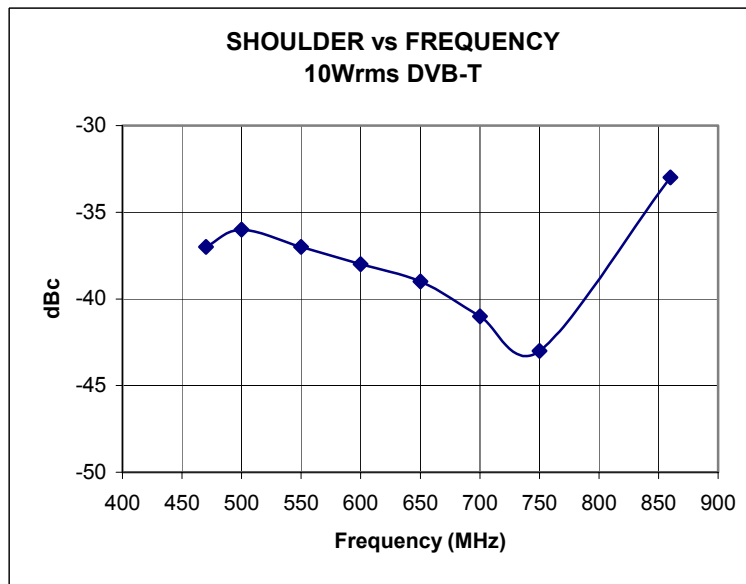

Without precorrection

Note: By the use of UBS DVB-T Modulator Mod. PT8750 + PT8731 option, and the proper precorrection, the AU20-D is able to deliver 30Wrms at better than -36dBc shoulders on all the band.

Contact Res-Ingenium, +39 0763 316333 Fax +39 0763316002- or visit www.res-ingenium.com for a complete listing.

Side View

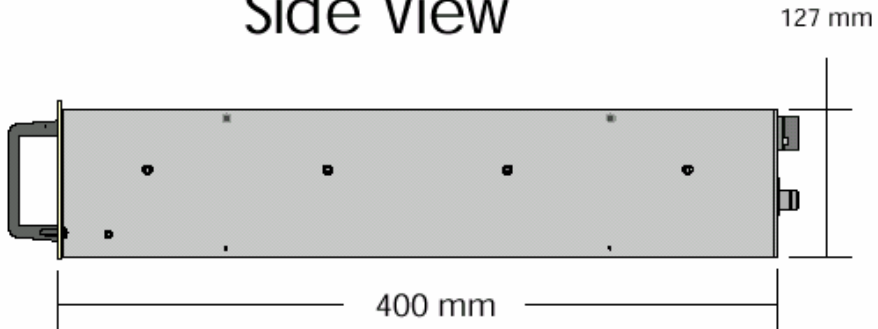

Top View



Contact Res-Ingenium, +39 0763 316333 Fax +39 0763316002- or visit www.res-ingenium.com for a complete listing.

GR00453	Issue: 0 Date: 30/11/2004	Rev: 2 Date: December 2006	Pag. 4/6
---------	------------------------------	-------------------------------	----------

Front Panel

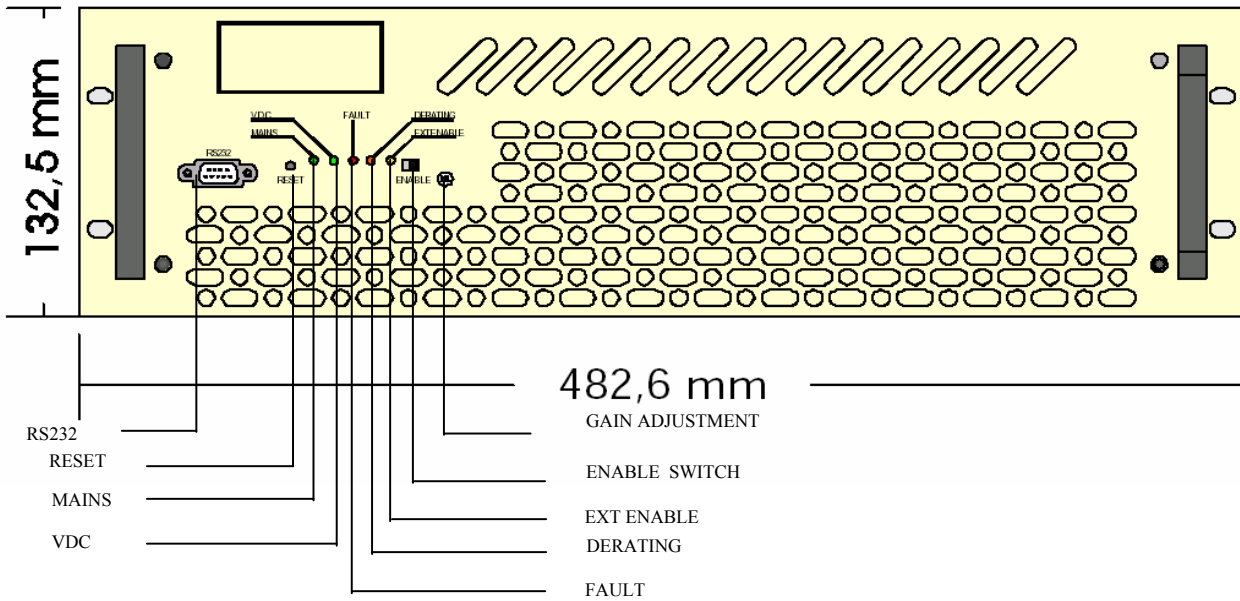

Rear Panel

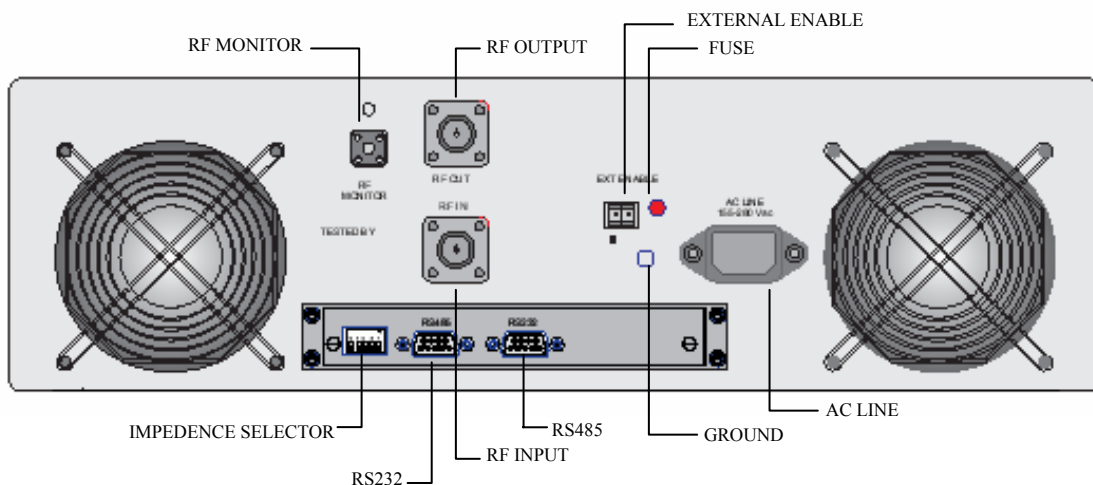

Contact Res-Ingenium, +39 0763 316333 Fax +39 0763316002- or visit www.res-ingenium.com for a complete listing.

Res-Ingenium

Via dei Vasari, 17
Zona Industriale Fontanelle di Bardano
05018 Orvieto (TR)
Italy
Telephone: +39 0736 316333
Fax: +39 0763 316002
Internet: res-ingenium.com
E-Mail: map@res-ingenium.com

IMPORTANT NOTICE

RES-INGENIUM RESERVE THE RIGHT TO MAKE CHANGES TO THE PRODUCT(S) OR INFORMATION CONTAINED HEREIN WITHOUT NOTICE. RES-INGENIUM ASSUMES NO RESPONSIBILITY FOR ANY ERRORS WHICH MAY APPEAR IN THIS DOCUMENT.

WARRANTY INFORMATION APPLICABLE TO THE PRODUCT IDENTIFIED HEREIN IS AVAILABLE UPON REQUEST. NOTHING CONTAINED HEREIN SHALL CONSTITUTE A WARRANTY, REPRESENTATION OR GUARANTEE OF ANY KIND. RES-INGENIUM EXPRESSLY DISCLAIMS ALL OTHER WARRANTIES, EXPRESS AND/OR IMPLIED INCLUDING BUT NOT LIMITED TO WARRANTIES OF MERCHANTABILITY, AND OF FITNESS FOR A PARTICULAR PURPOSE, USE OR APPLICATION.

No part of this document may be copied or reproduced in any form or by any means without the prior written consent of Res-Ingenium.

WARNING

RES-INGENIUM PRODUCTS ARE NOT INTENDED FOR USE IN LIFE SUPPORT APPLIANCES, DEVICES OR SYSTEMS. USE OF A RES-INGENIUM PRODUCT IN ANY SUCH APPLICATION WITHOUT WRITTEN CONSENT IS PROHIBITED.

Contact Res-Ingenium, +39 0763 316333 Fax +39 0763316002- or visit www.res-ingenium.com for a complete listing.

GR00453	Issue: 0 Date: 30/11/2004	Rev: 2 Date: December 2006	Pag. 6/6
---------	------------------------------	-------------------------------	----------