

Broadband Variable Gain Amplifier (VGA) 400 MHz - 20 GHz

Rev. V1

Features

- 12 dB Gain
- 50 Ω Input/Output Match over Gain Range
- 30 dB Gain Control with 0 to -2 V Control
- +18 dBm Output Power
- +5 V, -0.5 V DC, 70 mA
- Lead-Free 1.5 x 1.2 mm 6-lead TDFN Package
- RoHS* Compliant and 260°C Reflow Compatible

Description

The MAAM-011100 is an easy-to-use, broadband, general purpose variable gain amplifier. Its over 30 dB gain range is controlled by a single control pin and 50 Ω match is maintained over all settings.

The MAAM-011100 operates from 400 MHz to 20 GHz and features flat gain control from +10 dB to -20 dB. At maximum gain setting (V_C =Open) it delivers up to +18 dBm power and under 5 dB noise figure. Both reduce proportionally as gain is reduced with V_C . The input IP3 exceeds +15 dBm at max/min gain settings. The device is typically biased with a V_D = +5 V, V_G = -0.5 V, and a control of 0 V to -2 V. Typical current is 70 mA with V_G at -0.5 V

The MAAM-011100 is ideally suited for use as a power amplifier driver, gain trimming block, or temperature compensation in the receive or transmit mode. Typical applications include Wi-Fi, LTE, Point-to-Point, IMS, EW, and A&D systems.

This device is housed in a leadless 1.5 X 1.2 mm package that can be handled and placed with standard pick and place assembly equipment.

Ordering Information^{1,2}

Part Number	Package
MAAM-011100	bulk quantity
MAAM-011100-TR1000	1000 piece reel
MAAM-011100-001SMB	Sample board

1. Reference Application Note M513 for reel size information.
2. All sample boards include 5 loose parts.

* Restrictions on Hazardous Substances, European Union Directive 2002/95/EC.

Functional Schematic

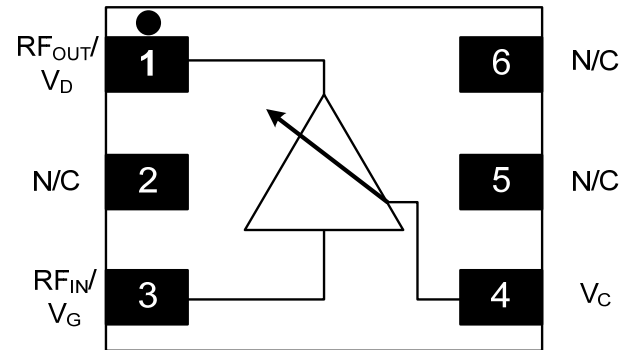

Pin Configuration

Pin No.	Pin Name	Function
1	RF _{OUT} /V _D	RF Output
2	N/C	No Connection
3	RF _{IN} /V _G	RF Input
4	V _C	Voltage Control
5	N/C	No Connection
6	N/C	No Connection
7	Paddle ³	Ground

3. The exposed pad centered on the package bottom must be connected to RF and DC ground.

Broadband Variable Gain Amplifier (VGA) 400 MHz - 20 GHz

Rev. V1

Electrical Specifications (unless otherwise noted):

Freq = 10 GHz, $T_A = +25^\circ\text{C}$, $V_D = +5\text{ V}$, $V_G = -0.5\text{ V}$, $V_C = \text{Open}$, $Z_{IN} = Z_{OUT} = 50\ \Omega$

Parameter	Test Conditions	Units	Min.	Typ.	Max.
Highest Gain	$V_C = \text{open @ 400 MHz}$ $V_C = \text{open @ 10 GHz}$ $V_C = \text{open @ 20 GHz}$	dB	8	12 10 11	—
Lowest Gain	$V_C = -2\text{ V @ 400 MHz}$ $V_C = -2\text{ V @ 10 GHz}$ $V_C = -2\text{ V @ 20 GHz}$	dB	—	-33 -23 -25	-18
Gain Control	$V_C = 0\text{ to }-2\text{ V}$	dB	—	30	—
Isolation	All States	dB	—	28	—
Input Return Loss	All States	dB	—	14	—
Output Return Loss	All States	dB	—	12	—
Noise Figure	At maximum gain	dB	—	5	—
P1dB	At maximum gain @ 10 GHz	dBm	—	+15	—
Input IP3	At maximum or minimum gain	dBm	—	+15	—
Stability	Any Load	-	unconditional		
Voltage Supply	External Choke	V	—	5	—
Bias Current	$V_D = +5\text{ V}$ $V_G = -0.5\text{ V}$	mA	—	75 0.01	—

Absolute Maximum Ratings^{4,5,6}

Parameter	Absolute Max.
Input Power	+15 dBm
Operating Voltage	+8 Volts
Operating Current	110 mA
Junction Temperature ⁷	+150°C
Operating Temperature	-40°C to +85°C
Storage Temperature	-65°C to +150°C

- Exceeding any one or combination of these limits may cause permanent damage to this device.
- M/A-COM Technology Solutions does not recommend sustained operation near these survivability limits.
- Operating at nominal conditions with $T_J \leq 150^\circ\text{C}$ will ensure $\text{MTTF} > 1 \times 10^6$ hours.
- Junction Temperature (T_J) = $T_C + \Theta_{JC} * ((V * I) - (P_{OUT} - P_{IN}))$
Typical thermal resistance (Θ_{JC}) = 67°C/W
 - For $T_C = 25^\circ\text{C}$,
 $T_J = 47^\circ\text{C @ 5 V, 70 mA, } P_{OUT} = 15\text{ dBm, } P_{IN} = 6\text{ dBm}$
 - For $T_C = 85^\circ\text{C}$,
 $T_J = 107^\circ\text{C @ 5 V, 70 mA, } P_{OUT} = 15\text{ dBm, } P_{IN} = 6\text{ dBm}$

Handling Procedures

Please observe the following precautions to avoid damage:

Static Sensitivity

Gallium Arsenide Integrated Circuits are sensitive to electrostatic discharge (ESD) and can be damaged by static electricity. Proper ESD control techniques should be used when handling these devices.

Evaluation Board

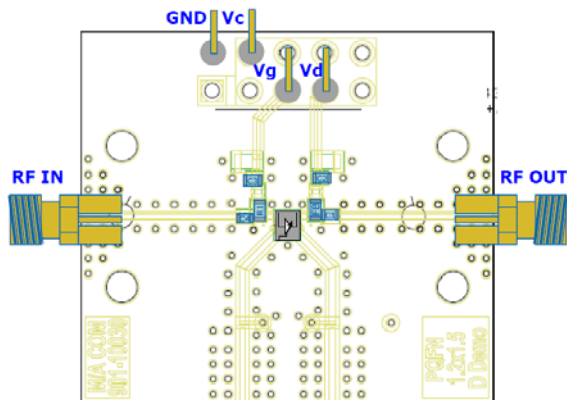

Application Schematic

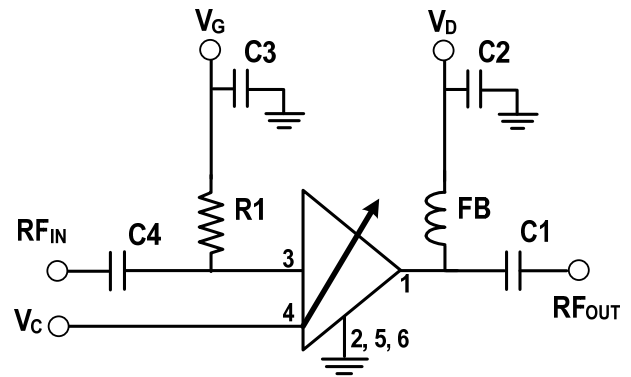

Recommended PCB Layout

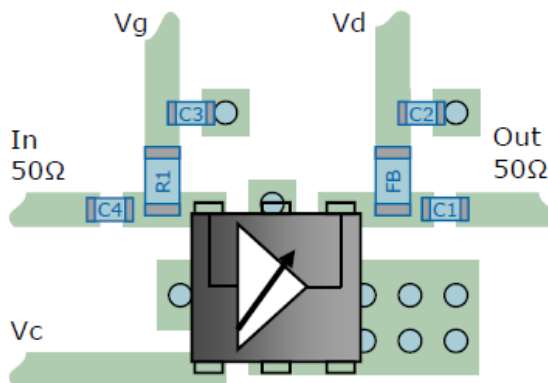

Application Information for DC & pins

For proper MAAM-011100 operation a DC voltage must be applied at the V_G (-0.5V) and V_D (+5V) pins *in that order*. Adjusting V_G from -0.2 V to -0.6 V will change the quiescent current which can effect power and linearity if set below or above 70 mA.

The gain of the MAAM-011100 is controlled with the V_C pin. The gain reduction is almost linear with V_C between 0 V to -2 V. Below -2 V internal ESD protection diodes will draw increasing current. The nominal open circuit voltage at the V_C pin is +1 V and produces maximum gain and power. Limiting applications and zero crossing adjustment can be done by adjusting the V_G and V_C pins together.

To bias properly, a DC voltage must be applied at the output pin. Typically this is done with a 2 element bias network that consists of a choke and a DC blocking capacitor. We recommend a ferrite bead for the main bias choke and quality capacitor for the DC block. A simple 1 K Ω resistor can be used as a RF choke for the negative V_G as applied to the input pin.

It is recommended that the total ground (common mode) inductance not exceed 0.03 nH (30 pH). This is equivalent to placing at least four 8-mil (200- μ m) diameter vias under the device, assuming an 8-mil (200- μ m) thick RF layer to ground

Parts List

Component	Value	Package
C1, C4	0.22 μ F	0201
C2, C3	0.22 μ F	0402
FB ⁸	407 Ω	0402
R1	1 K Ω	0402

8. M/A-COM Technology Solutions recommends using Murata part BLM15GG471.

Typical Performance Curves over Temperature

Gain, $V_C = 0\text{ V}, -2\text{ V}$

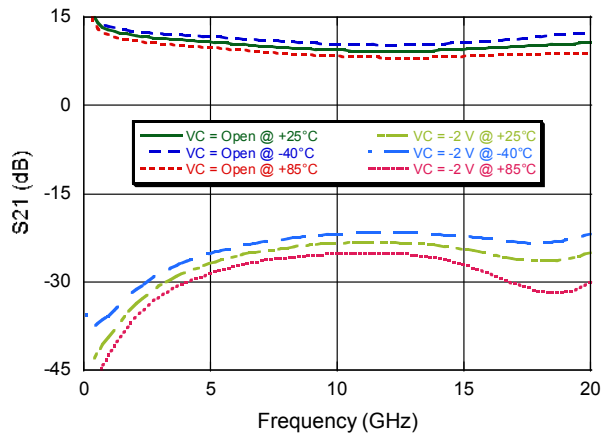

Return Loss

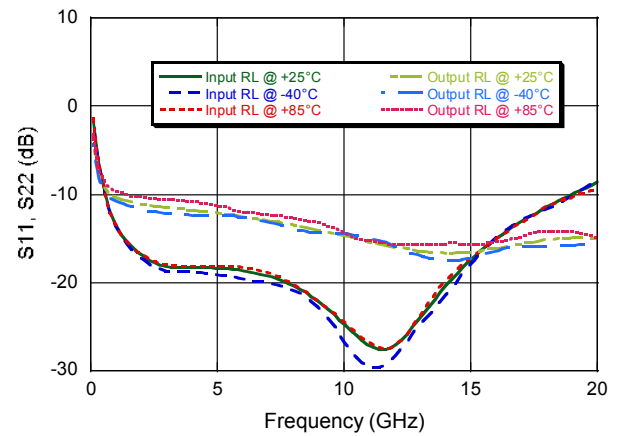

Reverse Isolation

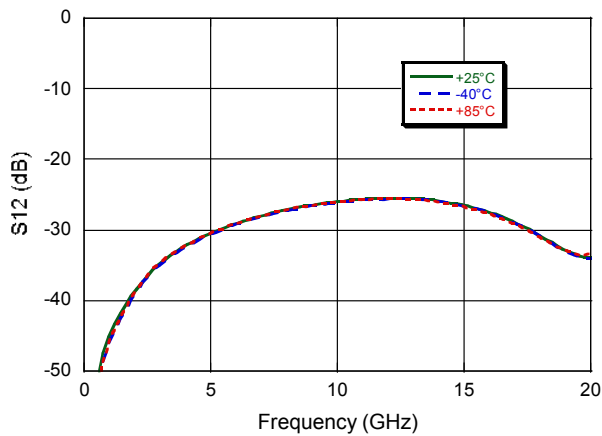

Noise Figure

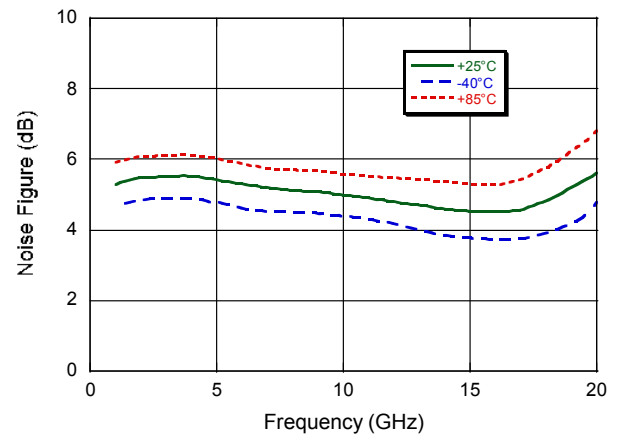

Output P1dB

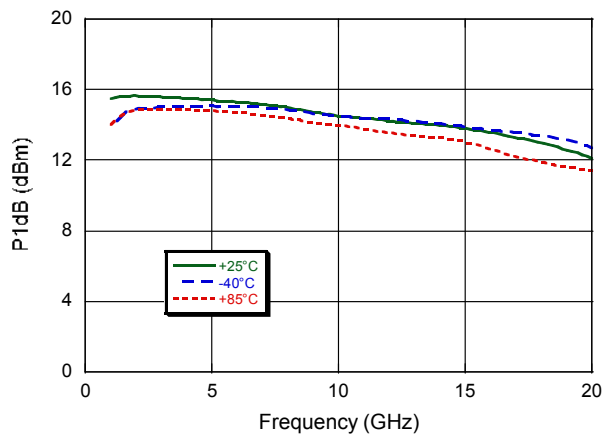

Input IP3

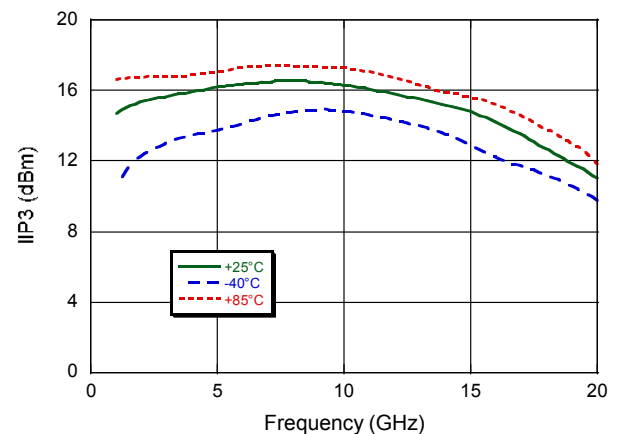

Typical Performance Curves vs. Control Voltage

Gain

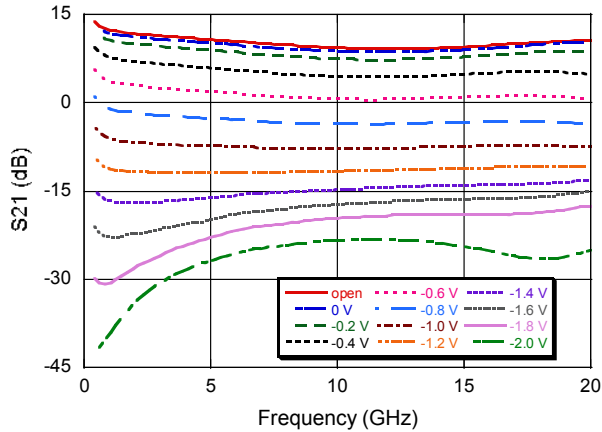

Noise Figure

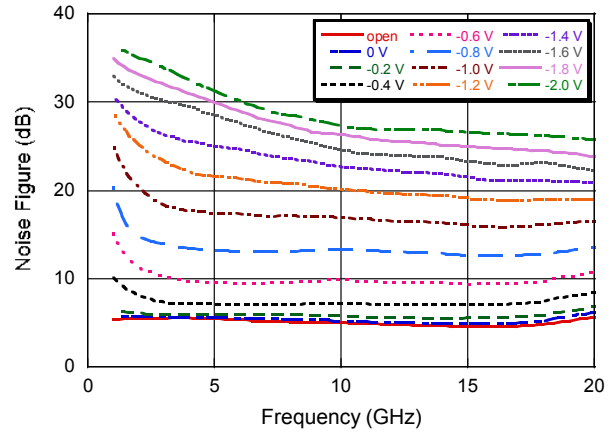

Input Return Loss

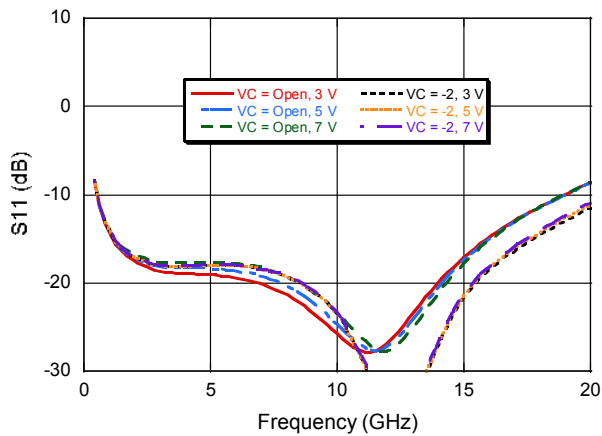

Output Return Loss

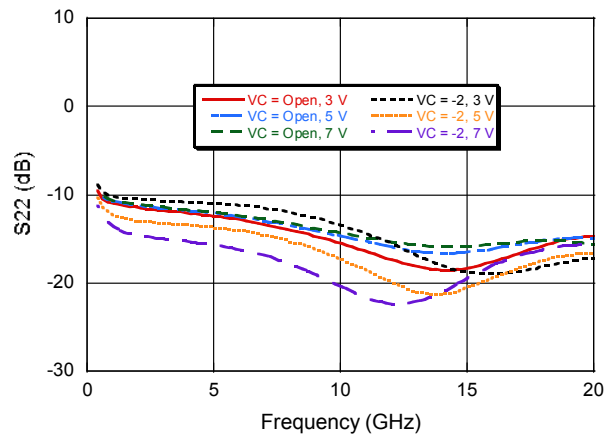

Output P1dB

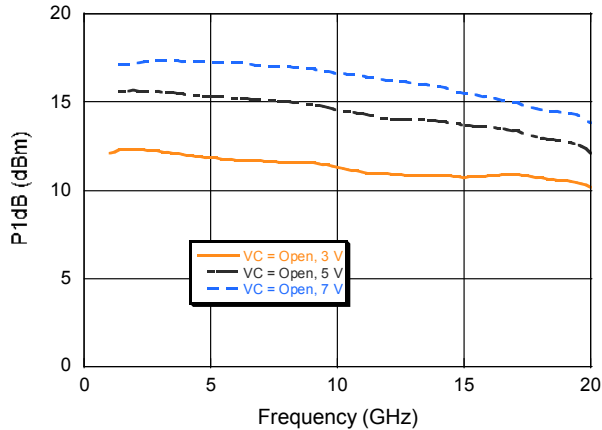

Input IP3

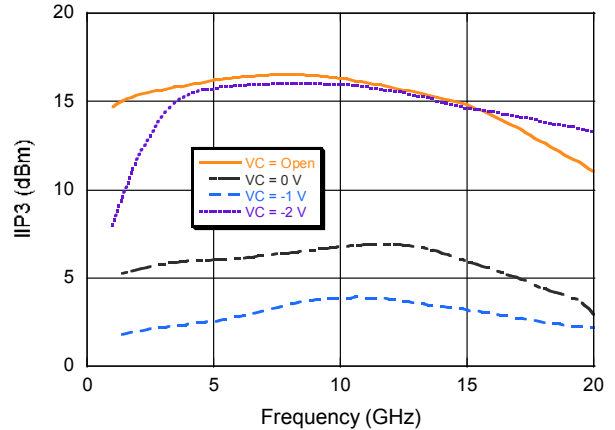

Typical Performance Curves

Saturated Power

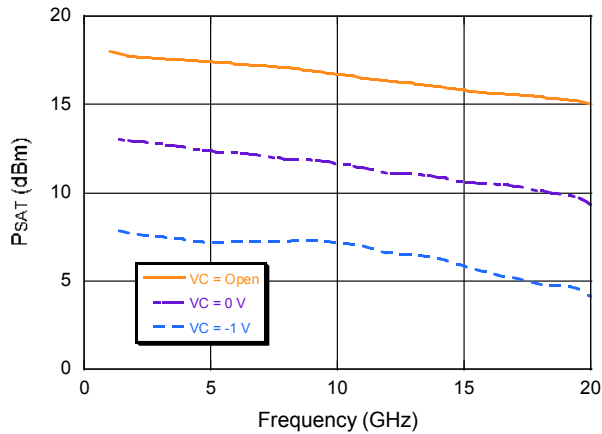

Saturated Power @ 10 GHz

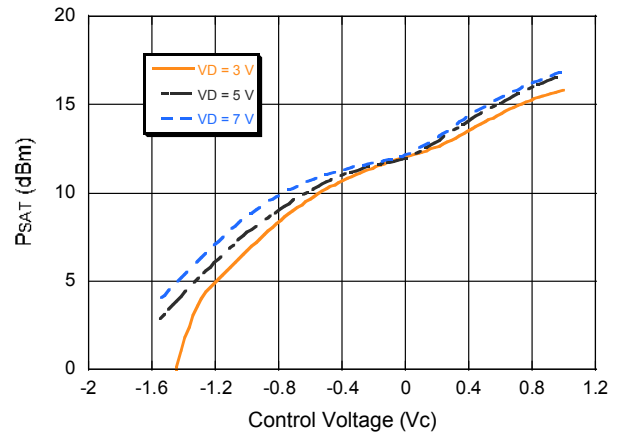

Gain @ 10 GHz

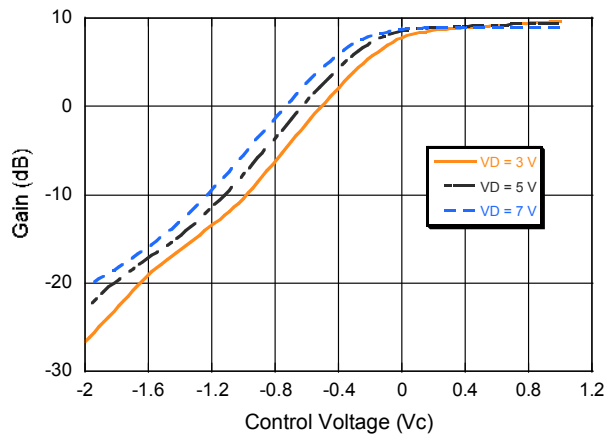

Noise Figure @ 10 GHz

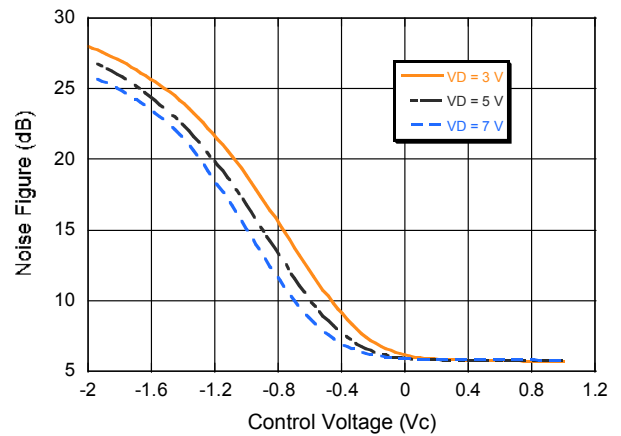

Input IP3 @ 10 GHz

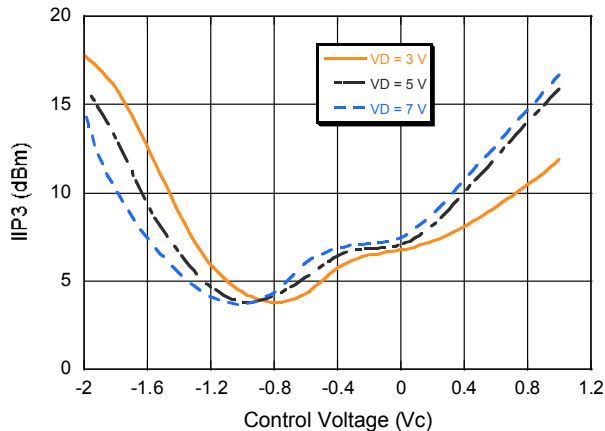

Current @ 10 GHz

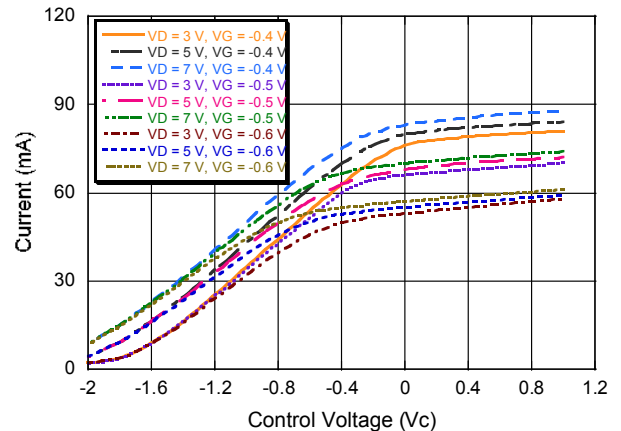

Lead-Free 1.5 x 1.2 mm 6-lead TDFN

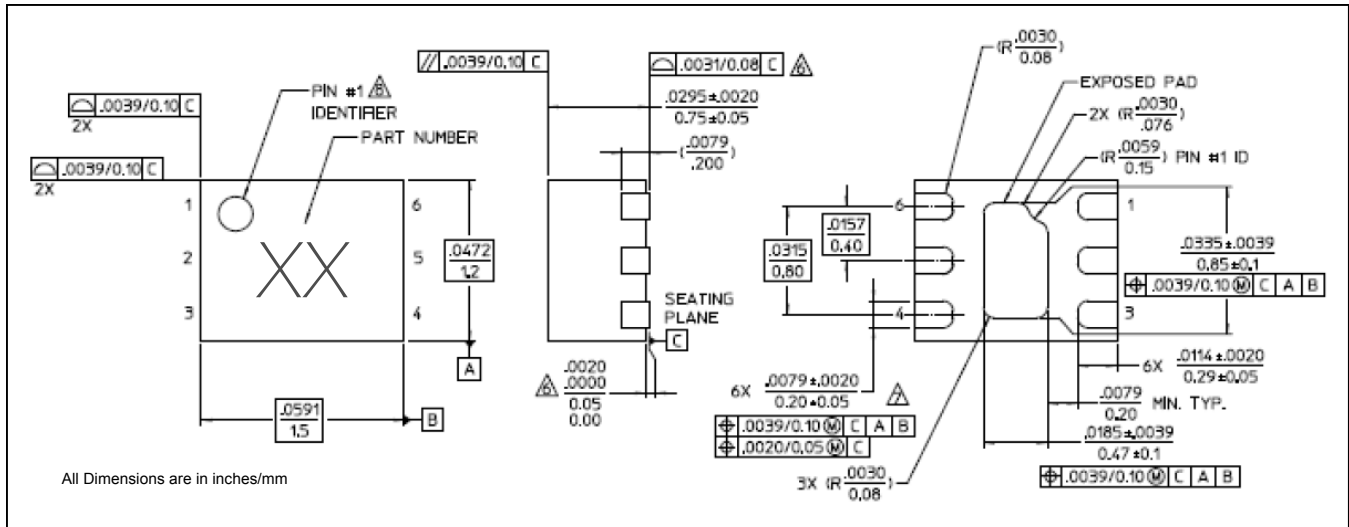

† Reference Application Note S2083 for lead-free solder reflow recommendations.
Meets JEDEC moisture sensitivity level 1 requirements.
Plating is matte tin over Copper.