

### Applications

- Point-to-Point Radio
- Linear C-band Sat-Com



42 lead 7x9mm QFN package

### Product Features

- Frequency Range: 7.1 – 8.5 GHz
- Power: 40 dBm Psat
- Gain: 28 dB
- TOI: 48 dBm at 30 dBm/tone
- Integrated Power Detector
- Bias: Vd1 = Vd2 = 6 V, Id1 + Id2 = 1000 mA, Vd3 = 28V, Id3 = 190mA
- Package Dimensions: 7.0 x 9.0 x 0.9 mm

### Functional Block Diagram

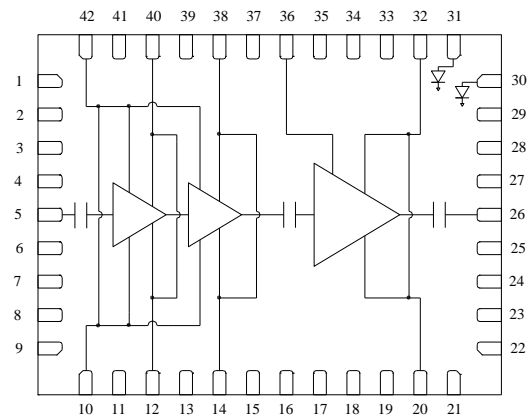

### General Description

The TriQuint TGA2752-SM is a C-Band Power Amplifier with integrated power detector. The TGA2752-SM operates from 7.1 – 8.5 GHz and is designed using TriQuint's power GaAs pHEMT and GaN HEMT production processes.

The TGA2752-SM typically provides 40 dBm of saturated output power with small signal gain of 28 dB. Third Order Intercept is 48 dBm at 30 dBm SCL.

The TG2752-SM is available in a low-cost, surface mount 42 lead 7x9 QFN package and is ideally suited for Point-to-Point Radio.

Lead-free and RoHS compliant

### Pin Configuration

Pin No.	Label
1, 2, 3, 4, 6, 7, 8, 9, 11, 13, 15, 16, 17, 18, 19, 21, 22, 23, 24, 25, 27, 28, 29, 33, 34, 35, 37, 39, 41	NC
5	RF IN
10, 42	Vg12
12, 40	Vd1
14, 38	Vd2
20, 32	Vd3
26	RF OUT
30	Vref
31	Vdet
36	Vg3

### Ordering Information

Part No.	ECCN	Description
TGA2752-SM	3A001.b.2.b.2	7.1-8.5GHz 10W Amp

Standard T/R size = 500 pieces on a 7" reel

### Absolute Maximum Ratings

Parameter	Rating
Drain Voltage, Vd1, Vd2	9 V
Drain Voltage, Vd3	32 V
Drain Current, Id1 + Id2	2443 mA
Drain Current, Id3	825 mA
Power Dissipation, Driver Stages, Pdiss	7.2 W
Power Dissipation, Final Stage, Pdiss	17 W
RF Input Power, CW, 50Ω, T = 25°C	29 dBm
GaAs Channel Temperature, Tch	200 °C
GaN Channel Temperature, Tch	275 °C
Mounting Temperature (30 Seconds)	260 °C
Storage Temperature	-40 to 150 °C

Operation of this device outside the parameter ranges given above may cause permanent damage. These are stress ratings only, and functional operation of the device at these conditions is not implied.

### Recommended Operating

Parameter	Min	Typ	Max	Units
Operating Temp. Range	-40	+25	+85	°C
Vd1, Vd2		6		V
Vd3		28		V
Id1 + Id2		1000		mA
Id3		190		mA
Vg12		-0.65		V
Vg3		-2.6		V
Id1 + Id2 drive (at 34 dBm Pout)		1050		mA
Id3 drive (at 34 dBm Pout)		400		mA

Electrical specifications are measured at specified test conditions. Specifications are not guaranteed over all recommended operating conditions.

### Electrical Specifications

Test conditions unless otherwise noted:  $V_{d1} = V_{d2} = +6\text{ V}$ ,  $I_{d1} + I_{d2} = 1000\text{ mA}$ ,  $V_{g12} = -0.65\text{ V}$ ,  $V_{d3} = +28\text{ V}$ ,  $I_{d3} = 190\text{ mA}$ ,  $V_{g3} = -2.6\text{ V}$ ,  $\text{Temp} = +25^\circ\text{C}$ ,  $Z_0 = 50\ \Omega$

Parameter	Min	Typ	Max	Units
RF Frequency Range	7.1		8.5	GHz
Small Signal Gain		28		dB
Input Return Loss, IRL		12		dB
Output Return Loss, ORL		15		dB
Output Power at Saturation, Psat		40		dBm
Output Power at 1dB Gain Compression, P1dB		30		dBm
Output Third Order Intercept, TOI @ 30 dBm/Tone		48		dBm
Gain Temperature Coefficient		-0.035		dB/°C
Power Temperature Coefficient		-0.012		dBm/°C

**Specifications**

**Thermal and Reliability Information (Driver Stages)**

Parameter	Conditions	Rating
Thermal Resistance, $\theta_{JC}$ , measured to back of package	Tbase = 85 °C	$\theta_{JC\_driver} = 9 \text{ }^\circ\text{C/W}$
Channel Temperature (Tch), and Median Lifetime (Tm)	Tbase = 85 °C Vd_driver = 6 V, Id_driver = 1000 mA Pdiss_driver = 6 W	Tch_driver = 139 °C Tm_driver = 2.6E+6 Hours
Channel Temperature (Tch), and Median Lifetime (Tm) at 34 dBm Pout	Tbase = 85 °C Vd_driver = 6 V, Id_driver = 1050 mA Pdiss_driver = 6.3 W	Tch_driver = 142 °C Tm_driver = 1.3E+6 Hours

**Median Lifetime vs. Channel Temperature**

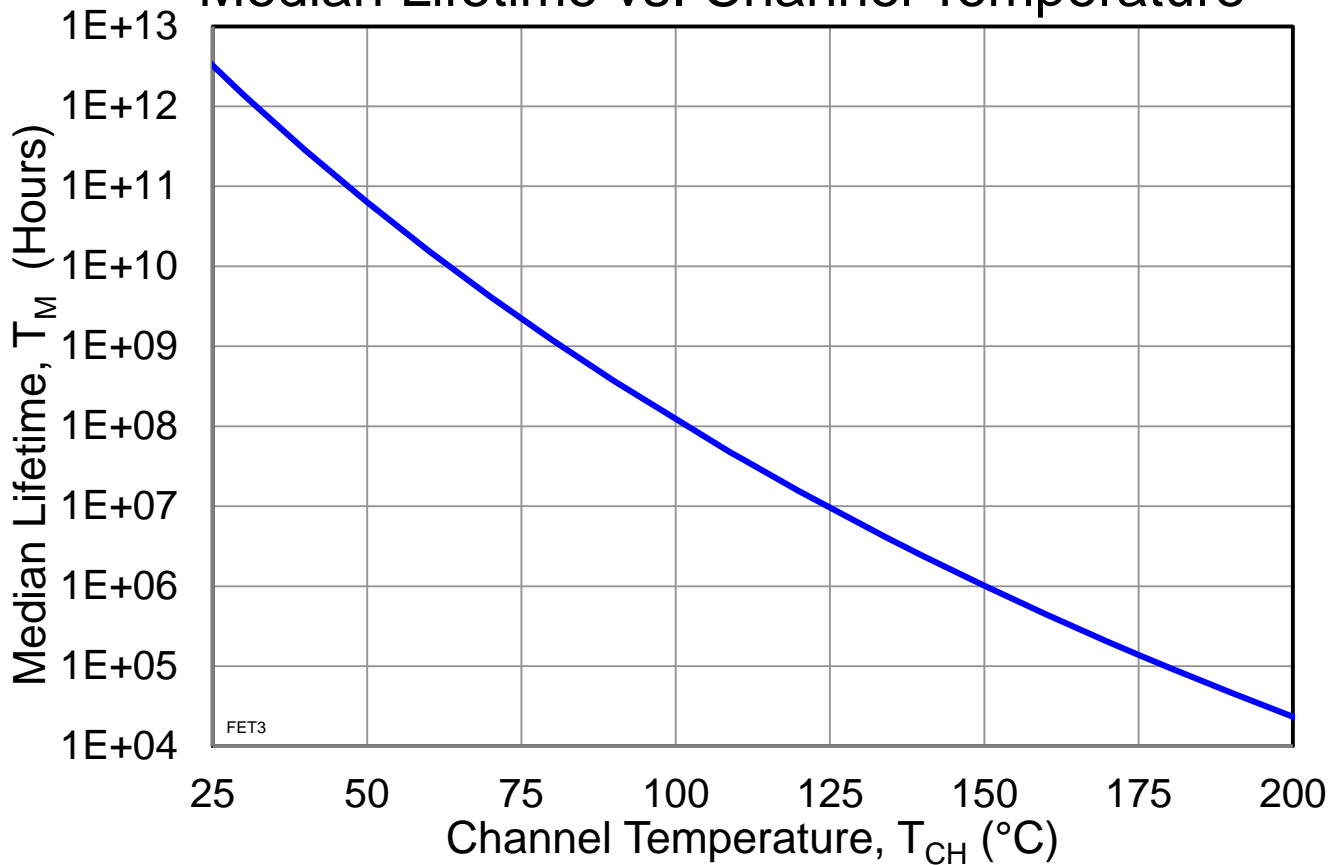

**Specifications**

**Thermal and Reliability Information (Final Stage)**

Parameter	Conditions	Rating
Thermal Resistance, $\theta_{JC}$ , measured to back of package	Tbase = 85 °C	$\theta_{JC\_final} = 8.2 \text{ }^\circ\text{C/W}$
Channel Temperature (Tch), and Median Lifetime (Tm)	Vd_final = 28 V, Id_final = 190 mA Pdiss_final = 5.3 W	Tch_final = 129 °C Tm_final = 2.01E+10 Hours
Channel Temperature (Tch), and Median Lifetime (Tm) at 34 dBm Pout	Vd_final = 28 V, Id_final = 400 mA Pdiss_final = 11.2 W	Tch_final = 177 °C Tm_final = 1.07E+8 Hours

**Median Lifetime vs. Channel Temperature**

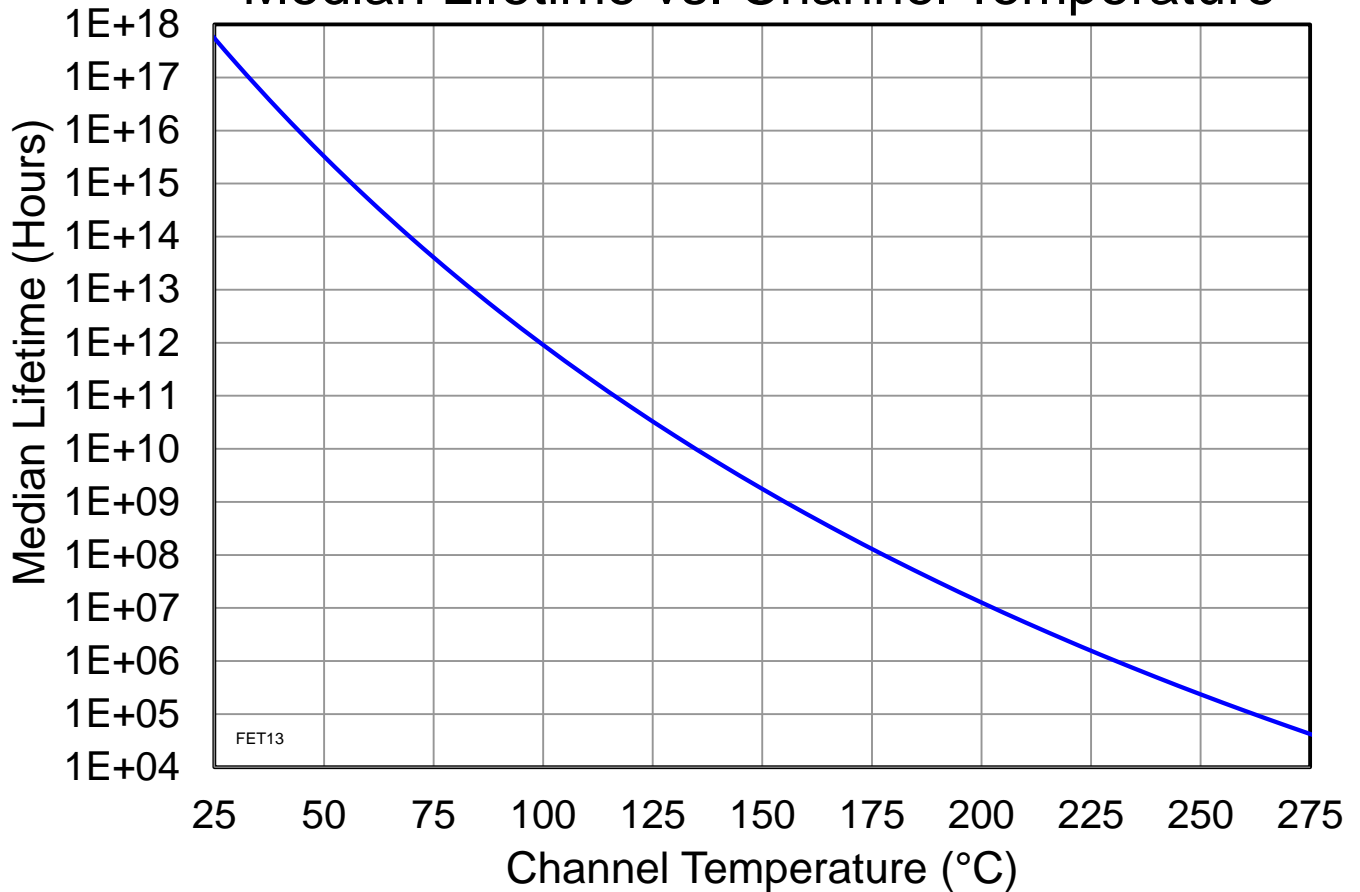

### Typical Performance

Test conditions unless otherwise noted:  $V_{d1} = V_{d2} = +6\text{ V}$ ,  $I_{d1} + I_{d2} = 1000\text{ mA}$ ,  $V_{g12} = -0.65\text{ V}$ ,  $V_{d3} = +28\text{ V}$ ,  $I_{d3} = 190\text{ mA}$ ,  $V_{g3} = -2.6\text{ V}$ ,  $\text{Temp} = +25^\circ\text{C}$ ,  $Z_0 = 50\ \Omega$

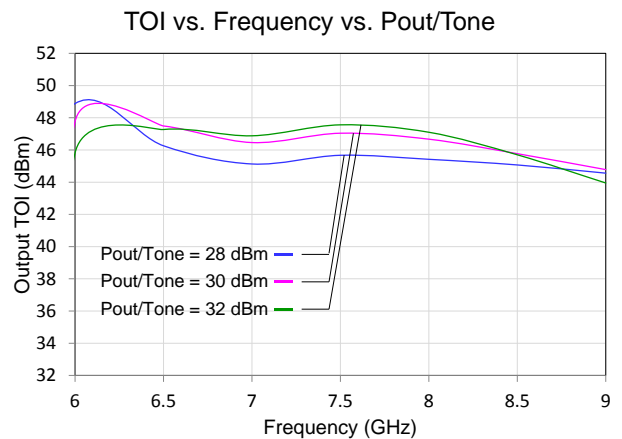
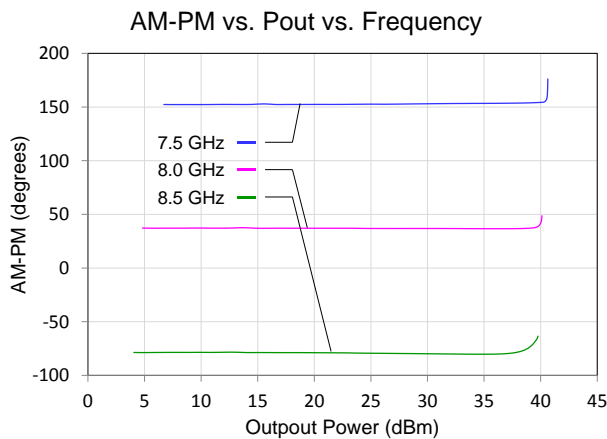
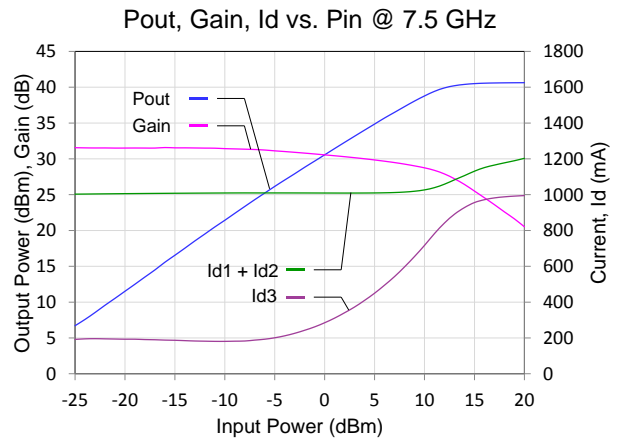
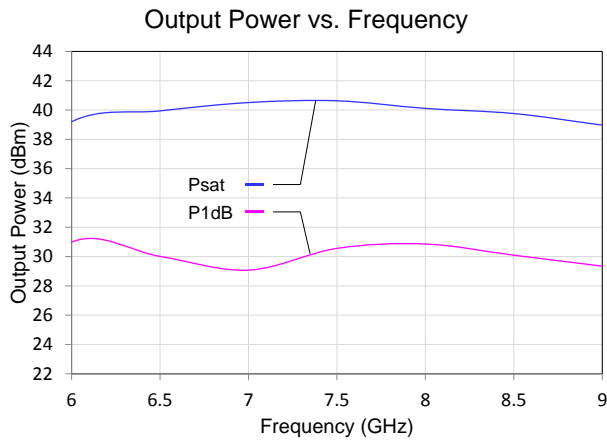
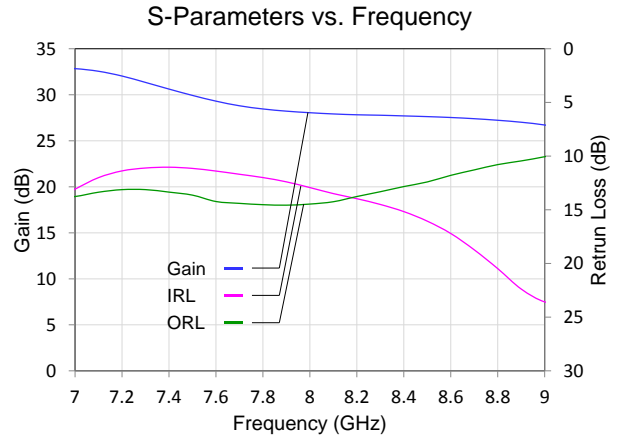
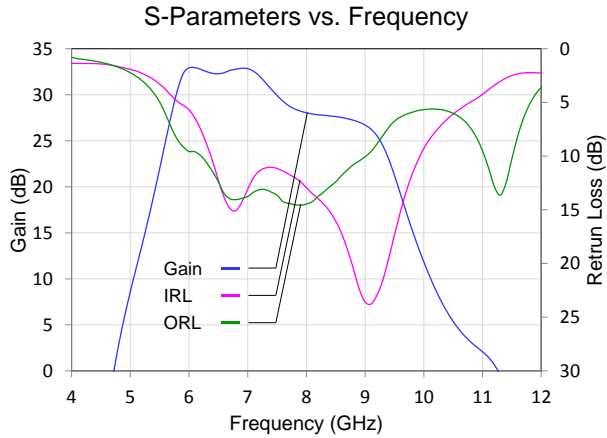

### Typical Performance

Test conditions unless otherwise noted:  $V_{d1} = V_{d2} = +6\text{ V}$ ,  $I_{d1} + I_{d2} = 1000\text{ mA}$ ,  $V_{g12} = -0.65\text{ V}$ ,  $V_{d3} = +28\text{ V}$ ,  $I_{d3} = 190\text{ mA}$ ,  $V_{g3} = -2.6\text{ V}$ ,  $\text{Temp} = +25^\circ\text{C}$ ,  $Z_0 = 50\ \Omega$

IM3 vs. Pout/Tone vs. Frequency

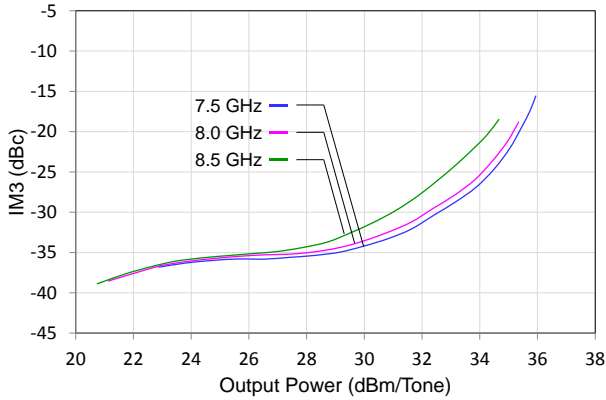

IM5 vs. Pout/Tone vs. Frequency

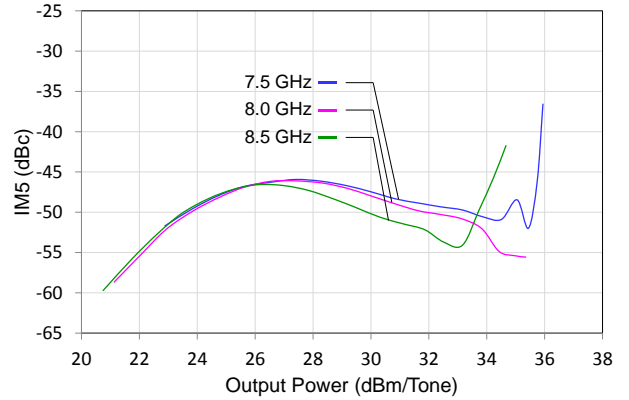

Gain vs. Frequency vs. Bias  
 $V_{d3} = 28\text{ V}$ ,  $I_{d3} = 190\text{ mA}$ ,  $V_{g3} = -2.6\text{ V}$  Typical

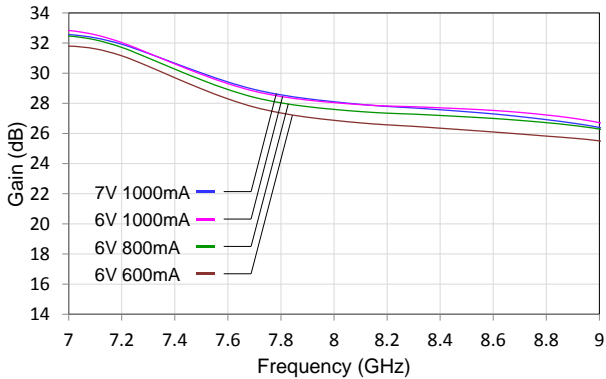

Gain vs. Frequency vs. Bias  
 $V_{d1} = V_{d2} = 6\text{ V}$ ,  $I_{d1} + I_{d2} = 1000\text{ mA}$ ,  $V_{g12} = -0.65\text{ V}$  Typical

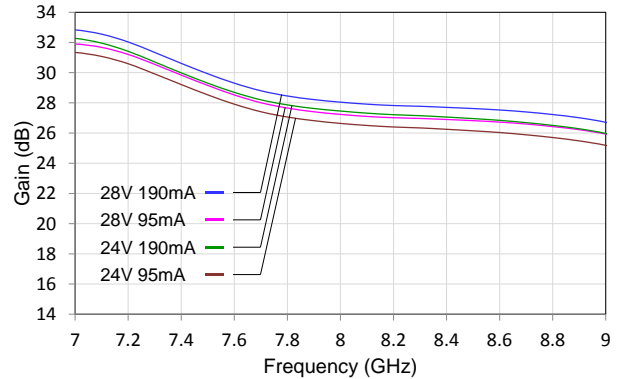

Psat vs. Frequency vs. Bias  
 $V_{d3} = 28\text{ V}$ ,  $I_{d3} = 190\text{ mA}$ ,  $V_{g3} = -2.6\text{ V}$  Typical

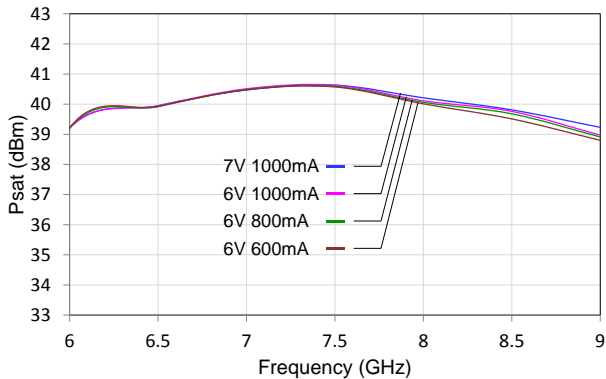

Psat vs. Frequency vs. Bias  
 $V_{d1} = V_{d2} = 6\text{ V}$ ,  $I_{d1} + I_{d2} = 1000\text{ mA}$ ,  $V_{g12} = -0.65\text{ V}$  Typical

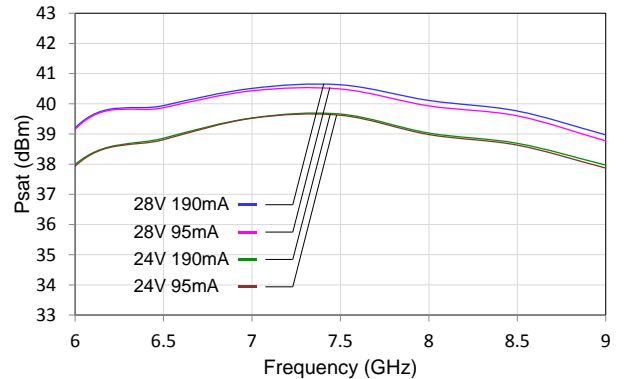

### Typical Performance

Test conditions unless otherwise noted:  $V_{d1} = V_{d2} = +6\text{ V}$ ,  $I_{d1} + I_{d2} = 1000\text{ mA}$ ,  $V_{g12} = -0.65\text{ V}$ ,  $V_{d3} = +28\text{ V}$ ,  $I_{d3} = 190\text{ mA}$ ,  $V_{g3} = -2.6\text{ V}$ ,  $\text{Temp} = +25^\circ\text{C}$ ,  $Z_0 = 50\ \Omega$

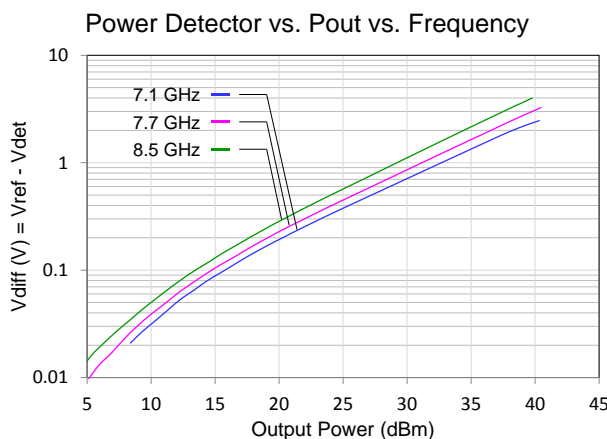
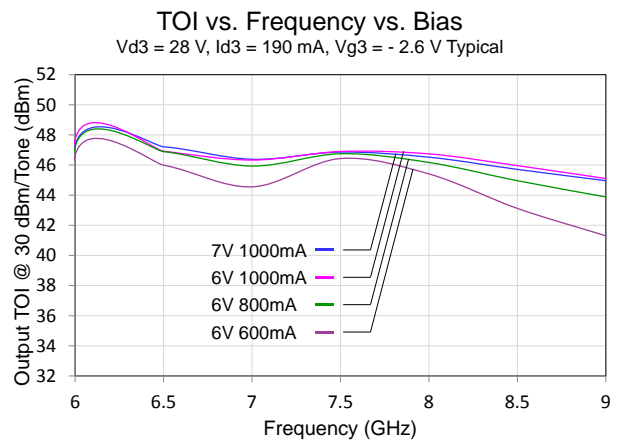
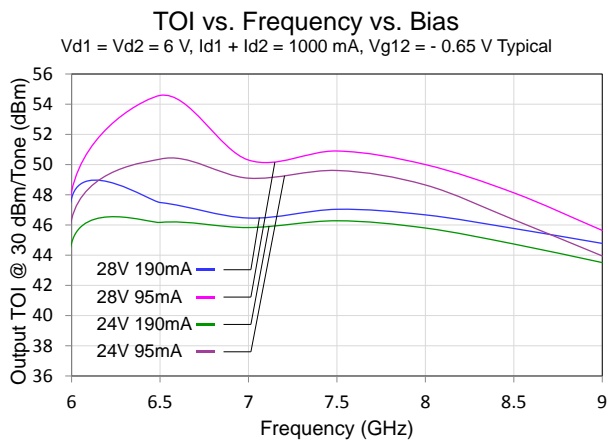
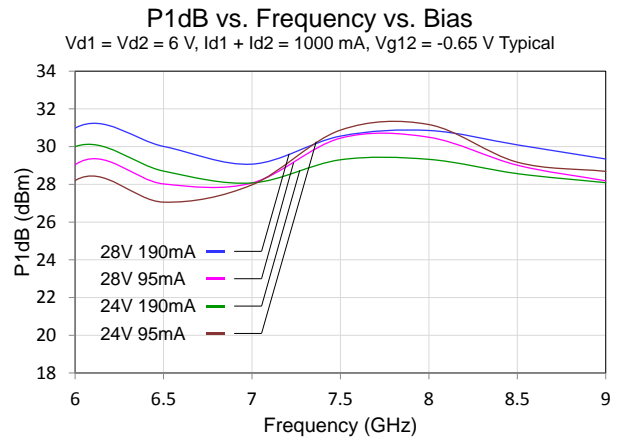
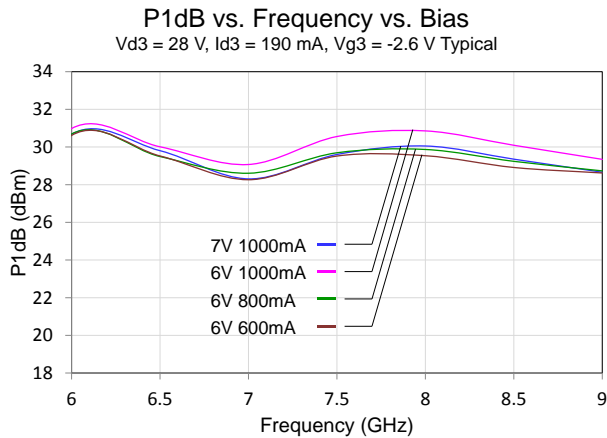



### Typical Performance

Test conditions unless otherwise noted:  $V_{d1} = V_{d2} = +6\text{ V}$ ,  $I_{d1} + I_{d2} = 1000\text{ mA}$ ,  $V_{g12} = -0.65\text{ V}$ ,  $V_{d3} = +28\text{ V}$ ,  $I_{d3} = 190\text{ mA}$ ,  $V_{g3} = -2.6\text{ V}$ ,  $\text{Temp} = +25^\circ\text{C}$ ,  $Z_0 = 50\ \Omega$

Gain vs. Frequency vs. Temperature

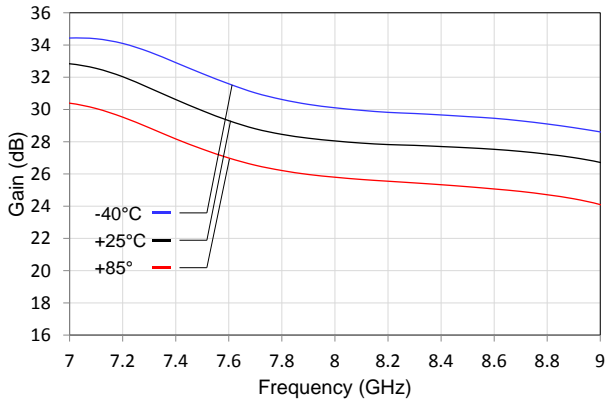

Psat vs. Frequency vs. Temperature

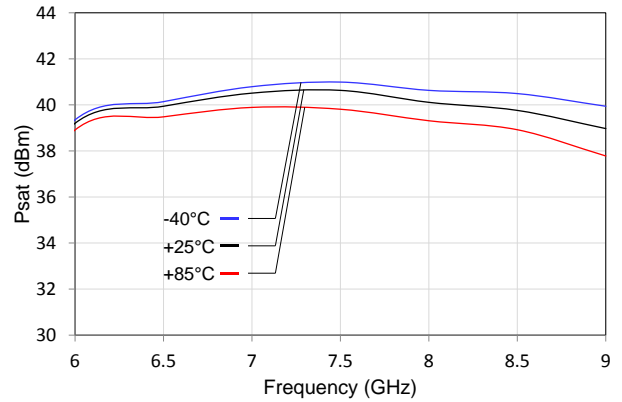

P1dB vs. Frequency vs. Temperature

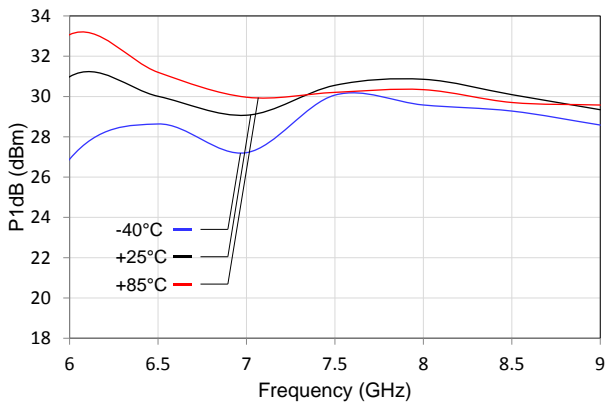

TOI vs. Frequency vs. Temperature

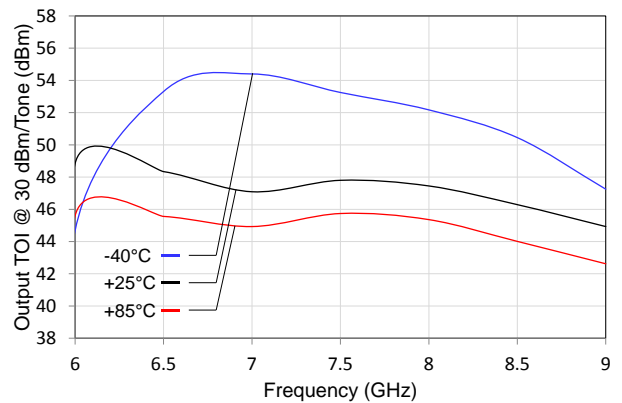

Power Detector vs. Pout vs. Temperature

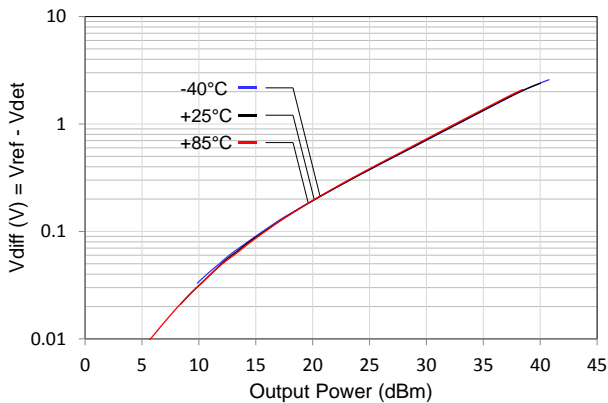

### Pin Configuration and Description

Top View

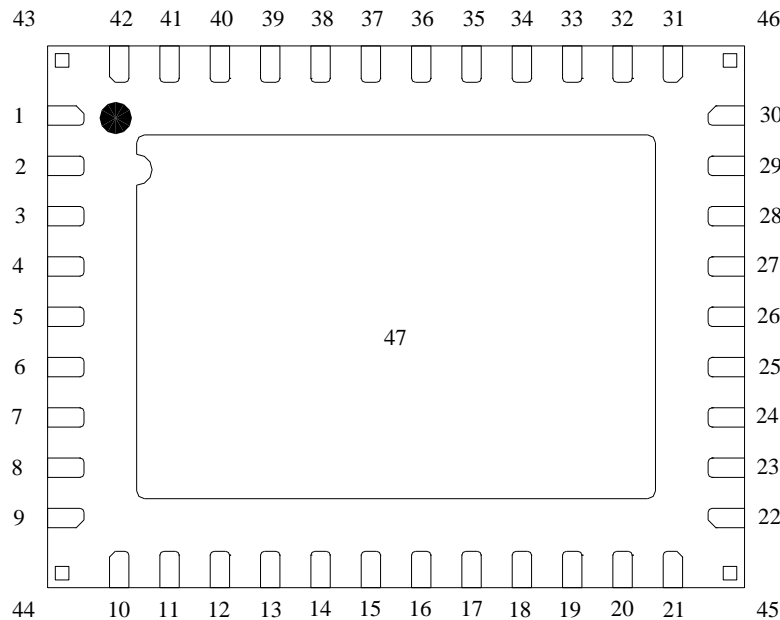

Pin No.	Label	Description
1, 2, 3, 4, 6, 7, 8, 9, 11, 13, 15, 16, 17, 18, 19, 21, 22, 23, 24, 25, 27, 28, 29, 33, 34, 35, 37, 39, 41	NC	No internal connection; must be grounded on PCB.
5	RF IN	RF Input, matched to 50 ohms, AC Coupled.
10, 42	Vg12	Gate voltage. Bias network is required; can be biased from either pin, and non-biased pin can be left open; see Application Circuit on page 11 as an example.
12, 40	Vd1	Drain voltage. Bias network is required; see Application Circuit on page 11 as an example.
14, 38	Vd2	Drain voltage. Bias network is required; see Application Circuit on page 11 as an example.
20, 32	Vd3	Drain voltage. Bias network is required; see Application Circuit on page 11 as an example.
26	RF OUT	RF Output, matched to 50 ohms, AC Coupled.
30	Vref	Reference diode output voltage.
31	Vdet	Detector diode output voltage. Varies with RF output power.
36	Vg3	Gate voltage. Bias network is required; see Application Circuit on page 11 as an example.
43, 44, 45, 46, 47	GND	Backside Paddle. Multiple vias should be employed to minimize inductance and thermal resistance; see Mounting Configuration on page 14 for suggested footprint.

### Application Circuit

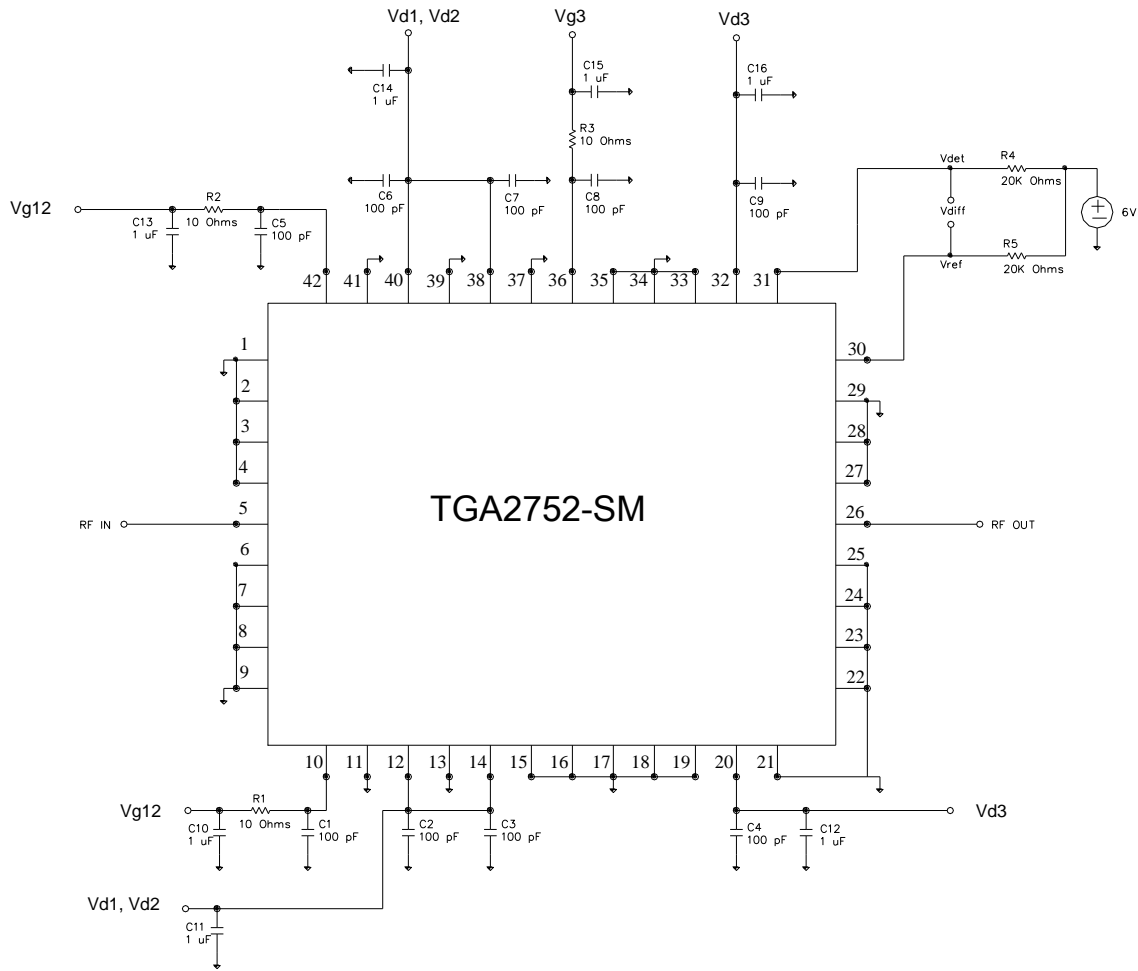

Vg12 can be biased from either side (pin 10 or pin 42), and the non-biased side can be left open. Vd1, Vd2, and Vd3 must be biased from both sides.

Bias-up Procedure	Bias-down Procedure
Vg12 set to -1.5 V	Turn off RF signal
Vg3 set to -3.5 V	Reduce Vg12 to -1.5V. Ensure Id ~ 0 mA
Vd1, Vd2 set to 6 V	Reduce Vg3 to -3.5V. Ensure Id ~ 0 mA
Vd3 set to 28 V	Turn Vd1, Vd2, Vd3 to 0 V
Adjust Vg12 more positive until quiescent Id is 1000 mA. This will be ~ Vg = -0.65 V typical	Turn Vg12, Vg3 to 0 V
Adjust Vg3 more positive until quiescent Id is 190 mA. This will be ~ Vg = -2.6 V typical	
Apply RF signal	

### Application Circuit

#### PC Board Layout

Board material is RO4003 0.008" thickness with ½ oz copper cladding.

For further technical information, refer to the [TGA2752-SM](#) Product Information page.

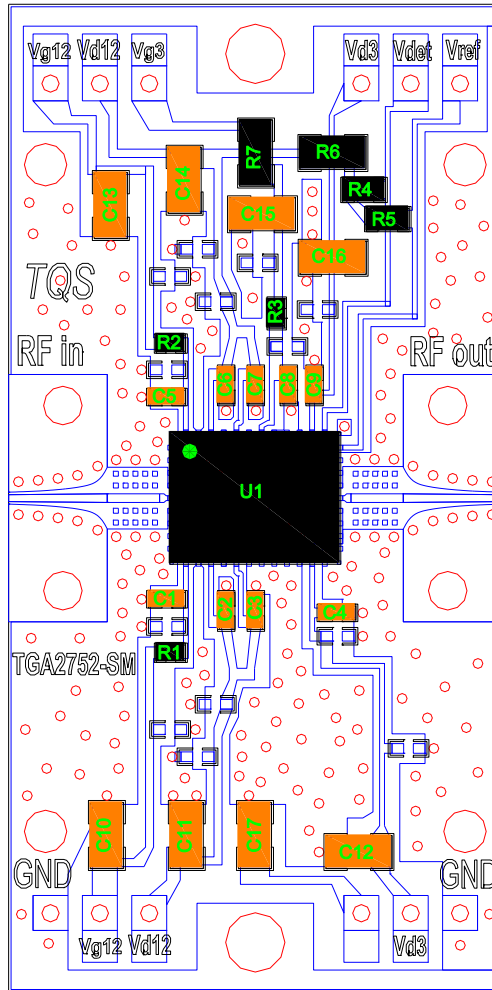

#### Bill of Material

Ref Des	Value	Description	Manufacturer	Part Number
C1 – C9	100 pF	Cap, 0402, 50V, 5%, C0G	various	
C10 – C17	1 µF	Cap, 0603, 50V, 5%, X5R	various	
R1 – R3	10 Ω	Res, 0402, 1/16W, 5%, SMD	various	
R4, R5	20 KΩ	Res, 0603, 1/16W, 5%, SMD	various	
R6, R7	0 Ω	Res, 0805, 1/16W, 5%, SMD	various	
U1		7.1 – 8.5 GHz Power Amplifier	Triquint	TGA2752-SM

### Mechanical Information

#### Package Marking and Dimensions

All dimensions are in millimeters.

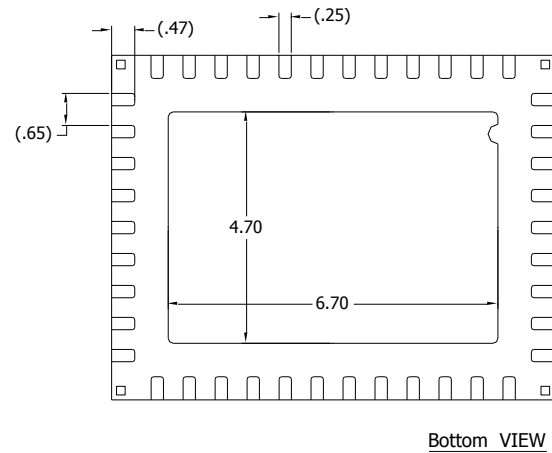
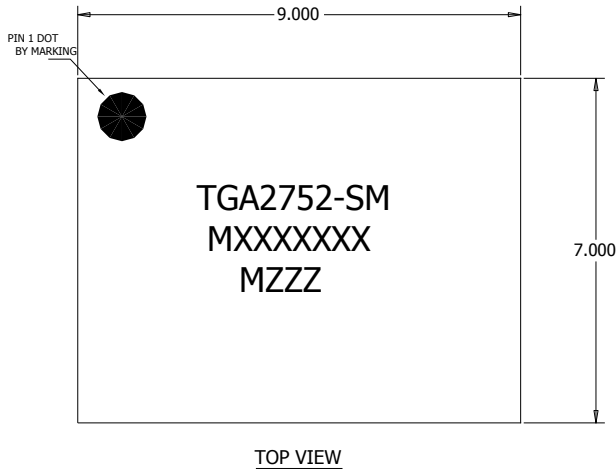

<b>A</b>		SLP
	MAX.	0.900
	NOM.	0.850
	MIN.	0.800

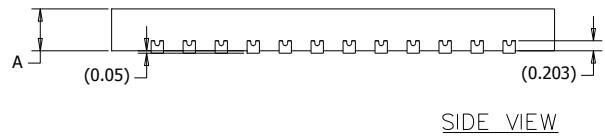

The TGA2752-SM will be marked with the “TGA2752-SM” designator and a lot code marked below the part designator. The “MXXXXXXXX” represents the lot number. The “ZZZ” is a unique serial number.

This package is lead-free/RoHS-compliant with a copper alloy base (CDA194), and the plating material on the leads is NiPdAu. It is compatible with lead-free (maximum 260 °C reflow temperature) soldering process.

**Mechanical Information**

**PCB Mounting Pattern**

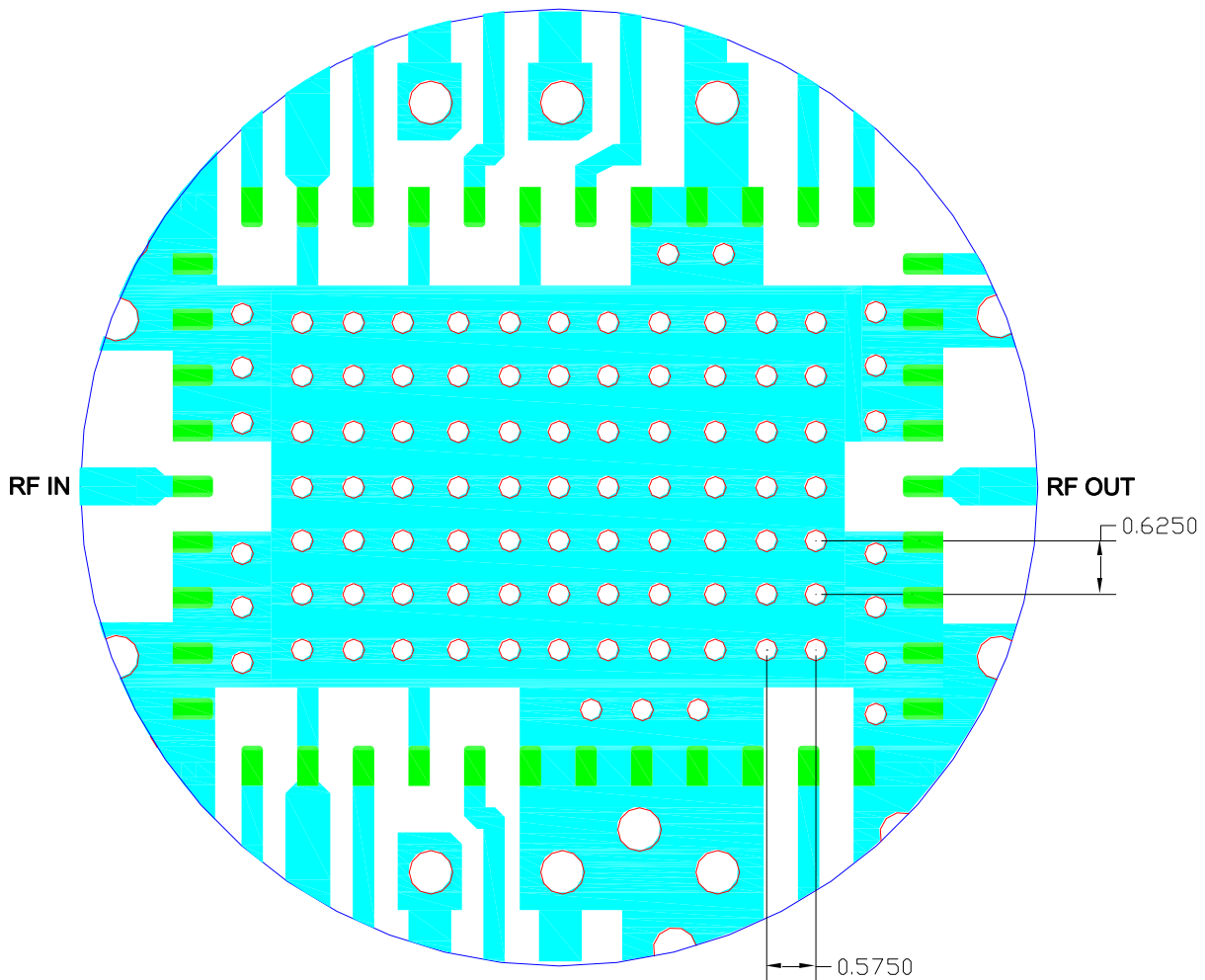

**Notes:**

1. The pad pattern shown has been developed and tested for optimized assembly at TriQuint Semiconductor. The PCB land pattern has been developed to accommodate lead and package tolerances. Since surface mount processes vary from company to company, careful process development is recommended.
2. Ground vias are critical for the proper performance of this device. Vias should use a .35mm (#80 / .0135") diameter drill and have a final plated thru diameter of .25 mm (.010").
3. For best thermal performance, vias under the ground paddle should be copper filled.

### Tape and Reel Information

Standard T/R size = 500 pieces on a 7" reel.

Material		Cavity (mm)				Distance Between Centerline (mm)		Carrier Tape (mm)	Cover Carrier (mm)
Vendor	Vendor P/N	Length (A0)	Width (B0)	Depth (K0)	Pitch (P1)	Length direction (P2)	Width Direction (F)	Width (W)	Width (W)
Tek-Pak	QFN0500X0 500F-L500	9.3	7.3	1.2	12.0	2.00	5.50	16.0	9.20

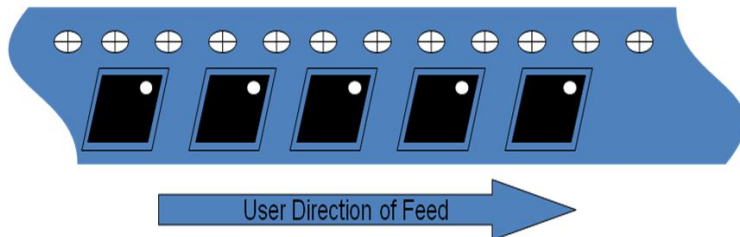
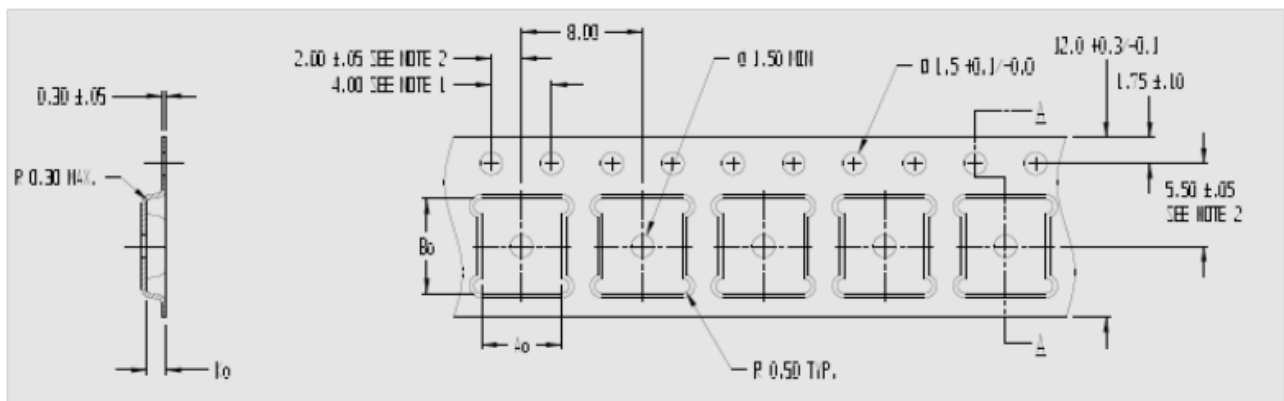

**Product Compliance Information**

**ESD Sensitivity Ratings**



Caution! ESD-Sensitive Device

ESD Rating: Class 1A  
 Value: Passed 250 V  
 Test: Human Body Model (HBM)  
 Standard: JEDEC Standard JESD22-A114

**MSL Rating**

MSL Rating: Level 3  
 Test: 260°C convection reflow  
 Standard: JEDEC Standard IPC/JEDEC J-STD-020

**Solderability**

Compatible with lead-free soldering processes, 260 °C maximum reflow temperature.

Package lead plating: NiPdAu.

**RoHs Compliance**

This part is compliant with EU 2002/95/EC RoHS directive (Restrictions on the Use of Certain Hazardous Substances in Electrical and Electronic Equipment).

This product also has the following attributes:

- Lead Free
- Halogen Free (Chlorine, Bromine)
- Antimony Free
- TBBP-A (C<sub>15</sub>H<sub>12</sub>Br<sub>4</sub>O<sub>2</sub>) Free
- PFOS Free
- SVHC Free

**Recommended Solder Temperature Profile**

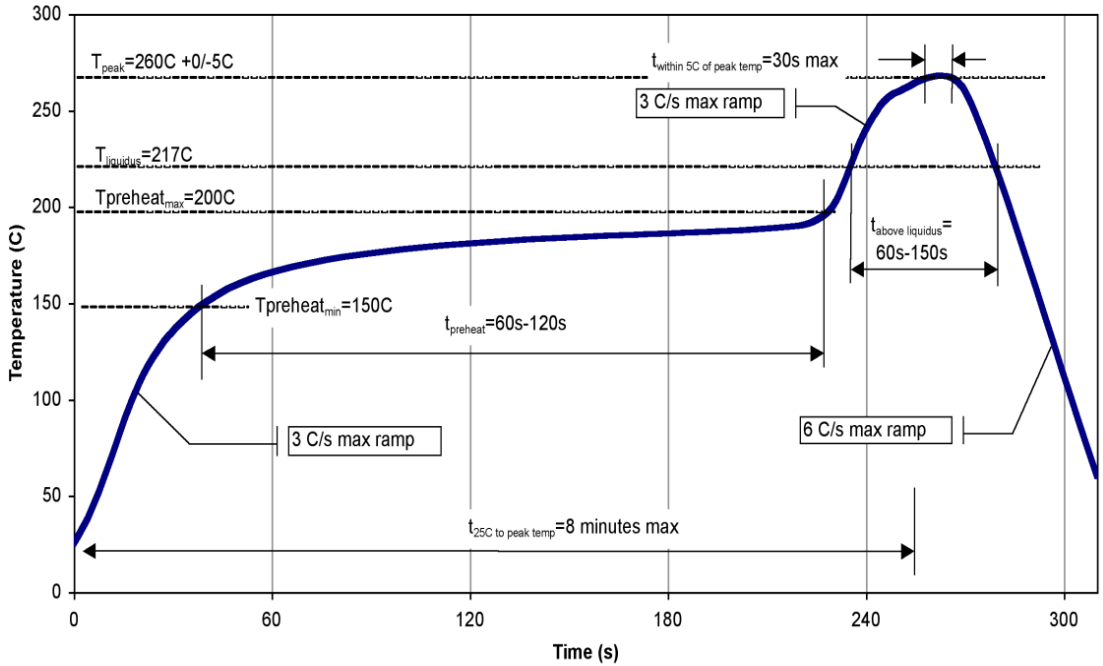



## Contact Information

For the latest specifications, additional product information, worldwide sales and distribution locations, and information about TriQuint:

**Web:** [www.triquint.com](http://www.triquint.com)  
**Email:** [info-sales@tqs.com](mailto:info-sales@tqs.com)

**Tel:** +1.972.994.8465  
**Fax:** +1.972.994.8504

For technical questions and application information: **Email:** [info-networks@tqs.com](mailto:info-networks@tqs.com)

## Important Notice

The information contained herein is believed to be reliable. TriQuint makes no warranties regarding the information contained herein. TriQuint assumes no responsibility or liability whatsoever for any of the information contained herein. TriQuint assumes no responsibility or liability whatsoever for the use of the information contained herein. The information contained herein is provided "AS IS, WHERE IS" and with all faults, and the entire risk associated with such information is entirely with the user. All information contained herein is subject to change without notice. Customers should obtain and verify the latest relevant information before placing orders for TriQuint products. The information contained herein or any use of such information does not grant, explicitly or implicitly, to any party any patent rights, licenses, or any other intellectual property rights, whether with regard to such information itself or anything described by such information.

TriQuint products are not warranted or authorized for use as critical components in medical, life-saving, or life-sustaining applications, or other applications where a failure would reasonably be expected to cause severe personal injury or death.