

# DATA SHEET

# NEC

## GaAs INTEGRATED CIRCUIT $\mu$ PG2181T5R

### HIGH POWER DP4T SWITCH FOR WiMAX

#### DESCRIPTION

The  $\mu$ PG2181T5R is a GaAs MMIC high power DP4T switch which was developed for WiMAX.

This device can operate frequency from 2.3 to 3.8 GHz, having the low insertion loss and high isolation.

This device is housed in a 20-pin plastic RQFN (Rectangle Quad Flat Non-leaded) package. And this package is able to high-density surface mounting.

#### FEATURES

- Supply voltage :  $V_{DD} = 2.8$  to  $3.2$  V (3.0 V TYP.)
- Control voltage :  $V_{cont(H)} = 1.5$  to  $V_{DD}$  ( $V_{DD}$  TYP.)  
:  $V_{cont(L)} = 0$  to  $0.2$  V (0 V TYP.)
- Low insertion loss :  $L_{ins1} = 0.8$  dB TYP. @  $f = 2.3$  to  $2.7$  GHz,  $V_{DD} = 3.0$  V,  $V_{cont(H)} = 3.0$  V,  $V_{cont(L)} = 0$  V  
:  $L_{ins2} = 1.0$  dB TYP. @  $f = 3.3$  to  $3.8$  GHz,  $V_{DD} = 3.0$  V,  $V_{cont(H)} = 3.0$  V,  $V_{cont(L)} = 0$  V
- High isolation :  $ISL1 = 28$  dB TYP. @  $f = 2.3$  to  $2.7$  GHz, Tx to Rx,  $V_{DD} = 3.0$  V,  $V_{cont(H)} = 3.0$  V,  $V_{cont(L)} = 0$  V  
:  $ISL2 = 24$  dB TYP. @  $f = 3.3$  to  $3.8$  GHz, Tx to Rx,  $V_{DD} = 3.0$  V,  $V_{cont(H)} = 3.0$  V,  $V_{cont(L)} = 0$  V  
:  $ISL3 = 25$  dB TYP. @  $f = 2.3$  to  $2.7$  GHz, Tx to ANT,  $V_{DD} = 3.0$  V,  $V_{cont(H)} = 3.0$  V,  $V_{cont(L)} = 0$  V  
:  $ISL4 = 21$  dB TYP. @  $f = 3.3$  to  $3.8$  GHz, Tx to ANT,  $V_{DD} = 3.0$  V,  $V_{cont(H)} = 3.0$  V,  $V_{cont(L)} = 0$  V  
:  $ISL5 = 25$  dB TYP. @  $f = 2.3$  to  $2.7$  GHz, Rx to ANT,  $V_{DD} = 3.0$  V,  $V_{cont(H)} = 3.0$  V,  $V_{cont(L)} = 0$  V  
:  $ISL6 = 22$  dB TYP. @  $f = 3.3$  to  $3.8$  GHz, Rx to ANT,  $V_{DD} = 3.0$  V,  $V_{cont(H)} = 3.0$  V,  $V_{cont(L)} = 0$  V
- Handling power :  $P_{in(1dB)} = +40.0$  dBm TYP. @  $f = 2.5/3.5$  GHz, Tx to ANT,  $V_{DD} = 3.0$  V,  $V_{cont(H)} = 3.0$  V,  $V_{cont(L)} = 0$  V  
:  $P_{in(1dB)} = +35.0$  dBm TYP. @  $f = 2.5/3.5$  GHz, Rx to ANT,  $V_{DD} = 3.0$  V,  $V_{cont(H)} = 3.0$  V,  $V_{cont(L)} = 0$  V
- High-density surface mounting : 20-pin plastic RQFN package ( $2.5 \times 3.5 \times 0.6$  mm)

#### APPLICATION

- Antenna switch for WiMAX CPE (Customer Premise Equipment)

#### ORDERING INFORMATION

Part Number	Order Number	Package	Marking	Supplying Form
$\mu$ PG2181T5R-E2	$\mu$ PG2181T5R-E2-A	20-pin plastic RQFN (Pb-Free)	G2181	<ul style="list-style-type: none"><li>• Embossed tape 8 mm wide</li><li>• Pin 1, 6 face the perforation side of the tape</li><li>• Qty 3 kpcs/reel</li></ul>

**Remark** To order evaluation samples, contact your nearby sales office.

Part number for sample order:  $\mu$ PG2181T5R

**Caution** Observe precautions when handling because these devices are sensitive to electrostatic discharge.

The information in this document is subject to change without notice. Before using this document, please confirm that this is the latest version.  
Not all products and/or types are available in every country. Please check with an NEC Electronics sales representative for availability and additional information.

**PIN CONNECTIONS**

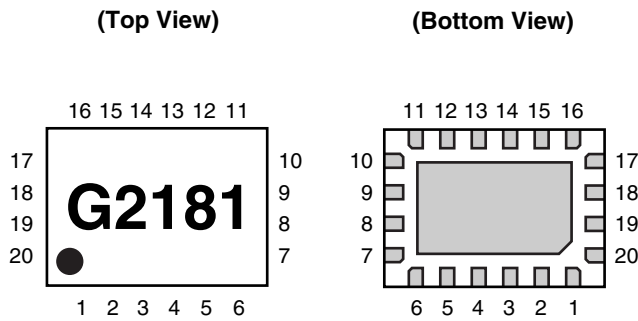

Pin No.	Pin Name	Pin No.	Pin Name
1	GND	11	GND
2	GND	12	ANT1
3	Rx	13	GND
4	GND	14	Tx
5	ANT4	15	GND
6	GND	16	GND
7	ANT3	17	V <sub>DD</sub>
8	GND	18	V <sub>cont2</sub>
9	GND	19	V <sub>cont1</sub>
10	ANT2	20	V <sub>cont0</sub>

**Remark** Exposed pad : GND

**TRUTH TABLE**

CONTROL VOLTAGE				ON PATH							
V <sub>DD</sub>	V <sub>cont0</sub>	V <sub>cont1</sub>	V <sub>cont2</sub>	Tx				Rx			
				ANT1	ANT2	ANT3	ANT4	ANT1	ANT2	ANT3	ANT4
High	Low	Low	Low	ON	OFF	OFF	OFF	OFF	OFF	OFF	OFF
High	High	Low	Low	OFF	ON	OFF	OFF	OFF	OFF	OFF	OFF
High	Low	High	Low	OFF	OFF	ON	OFF	OFF	OFF	OFF	OFF
High	High	High	Low	OFF	OFF	OFF	ON	OFF	OFF	OFF	OFF
High	Low	Low	High	OFF	OFF	OFF	OFF	ON	OFF	OFF	OFF
High	High	Low	High	OFF	OFF	OFF	OFF	OFF	ON	OFF	OFF
High	Low	High	High	OFF	OFF	OFF	OFF	OFF	OFF	ON	OFF
High	High	High	High	OFF	OFF	OFF	OFF	OFF	OFF	OFF	ON

**ABSOLUTE MAXIMUM RATINGS (T<sub>A</sub> = +25°C, unless otherwise specified)**

Parameter	Symbol	Ratings	Unit
Supply Voltage	V <sub>DD</sub>	4.2	V
Switch Control Voltage	V <sub>cont</sub>	4.2	V
Input Power-Tx (ON Port)	P <sub>in-Tx</sub>	+41	dBm
Input Power-Rx (ON Port)	P <sub>in-Rx</sub>	+36	dBm
Input Power-Tx (OFF Port)	P <sub>in-Tx (OFF)</sub>	+25	dBm
Input Power-Rx (OFF Port)	P <sub>in-Rx (OFF)</sub>	+25	dBm
Power Dissipation	P <sub>D</sub>	800	mW
Operating Ambient Temperature	T <sub>A</sub>	-45 to +85	°C
Storage Temperature	T <sub>stg</sub>	-55 to +150	°C

**RECOMMENDED OPERATING RANGE (T<sub>A</sub> = +25°C, unless otherwise specified)**

Parameter	Symbol	MIN.	TYP.	MAX.	Unit
Operating Frequency	f <sub>opt1</sub>	2.3	-	2.7	GHz
	f <sub>opt2</sub>	3.3	-	3.8	GHz
Supply Voltage	V <sub>DD</sub>	2.8	3.0	3.2	V
Switch Control Voltage (H)	V <sub>cont (H)</sub>	1.5	V <sub>DD</sub>	V <sub>DD</sub>	V
Switch Control Voltage (L)	V <sub>cont (L)</sub>	0	0	0.2	V

**ELECTRICAL CHARACTERISTICS**

( $T_A = +25^{\circ}\text{C}$ ,  $V_{DD} = 3.0\text{ V}$ ,  $V_{\text{cont}}(\text{H}) = 3.0\text{ V}$ ,  $V_{\text{cont}}(\text{L}) = 0\text{ V}$ , DC blocking capacitors = 6 pF,  $Z_0 = 50\ \Omega$ , unless otherwise specified)

Parameter	Symbol	Test Conditions	MIN.	TYP.	MAX.	Unit
Insertion Loss 1	L <sub>ins1</sub>	f = 2.3 to 2.7 GHz, Tx to ANT1/2/3/4	–	0.80	1.05	dB
Insertion Loss 2	L <sub>ins2</sub>	f = 3.3 to 3.8 GHz, Tx to ANT1/2/3/4	–	1.00	1.30	dB
Insertion Loss 3	L <sub>ins3</sub>	f = 2.3 to 2.7 GHz, Rx to ANT1/2/3/4	–	0.80	1.05	dB
Insertion Loss 4	L <sub>ins4</sub>	f = 3.3 to 3.8 GHz, Rx to ANT1/2/3/4	–	1.00	1.30	dB
Isolation 1	ISL1	f = 2.3 to 2.7 GHz, Tx to Rx	25	28	–	dB
Isolation 2	ISL2	f = 3.3 to 3.8 GHz, Tx to Rx	21	24	–	dB
Isolation 3	ISL3	f = 2.3 to 2.7 GHz, Tx to ANT1/2/3/4	22	25	–	dB
Isolation 4	ISL4	f = 3.3 to 3.8 GHz, Tx to ANT1/2/3/4	18	21	–	dB
Isolation 5	ISL5	f = 2.3 to 2.7 GHz, Rx to ANT1/2/3/4	22	25	–	dB
Isolation 6	ISL6	f = 3.3 to 3.8 GHz, Rx to ANT1/2/3/4	19	22	–	dB
On Port Return Loss 1	RL <sub>in1</sub>	f = 2.3 to 2.7 GHz, All Port	–	15	–	dB
On Port Return Loss 2	RL <sub>in2</sub>	f = 3.3 to 3.8 GHz, All Port	–	15	–	dB
Unused Port Return Loss 1	URL1	f = 2.3 to 2.7 GHz, Tx/Rx Port	–	13	–	dB
Unused Port Return Loss 2	URL2	f = 3.3 to 3.8 GHz, Tx/Rx Port	–	13	–	dB
1 dB Loss Compression Input Power <sup>Note</sup>	P <sub>in (1 dB)</sub>	f = 2.5 GHz, Tx to ANT1/2/3/4	–	+40.0	–	dBm
		f = 3.5 GHz, Tx to ANT1/2/3/4	–	+40.0	–	dBm
		f = 2.5 GHz, Rx to ANT1/2/3/4	–	+35.0	–	dBm
		f = 3.5 GHz, Rx to ANT1/2/3/4	–	+35.0	–	dBm
Output 3rd Order Intercept Point	OIP <sub>31</sub>	f = 2.5 GHz, Tx to ANT1/2/3/4	–	+63.0	–	dBm
	OIP <sub>32</sub>	f = 2.5 GHz, Rx to ANT1/2/3/4	–	+57.0	–	dBm
Supply Current	I <sub>DD</sub>	RF None	–	600	1 100	μA
Switch Control Current	I <sub>cont</sub>	RF None	–	1	2	μA
Switch Control Speed	t <sub>sw</sub>	50% CTL to 90/10% RF	–	250	–	ns

**Note** P<sub>in (1 dB)</sub> is measured the input power level when the insertion loss increases more 1 dB than that of linear range.

EVALUATION CIRCUIT

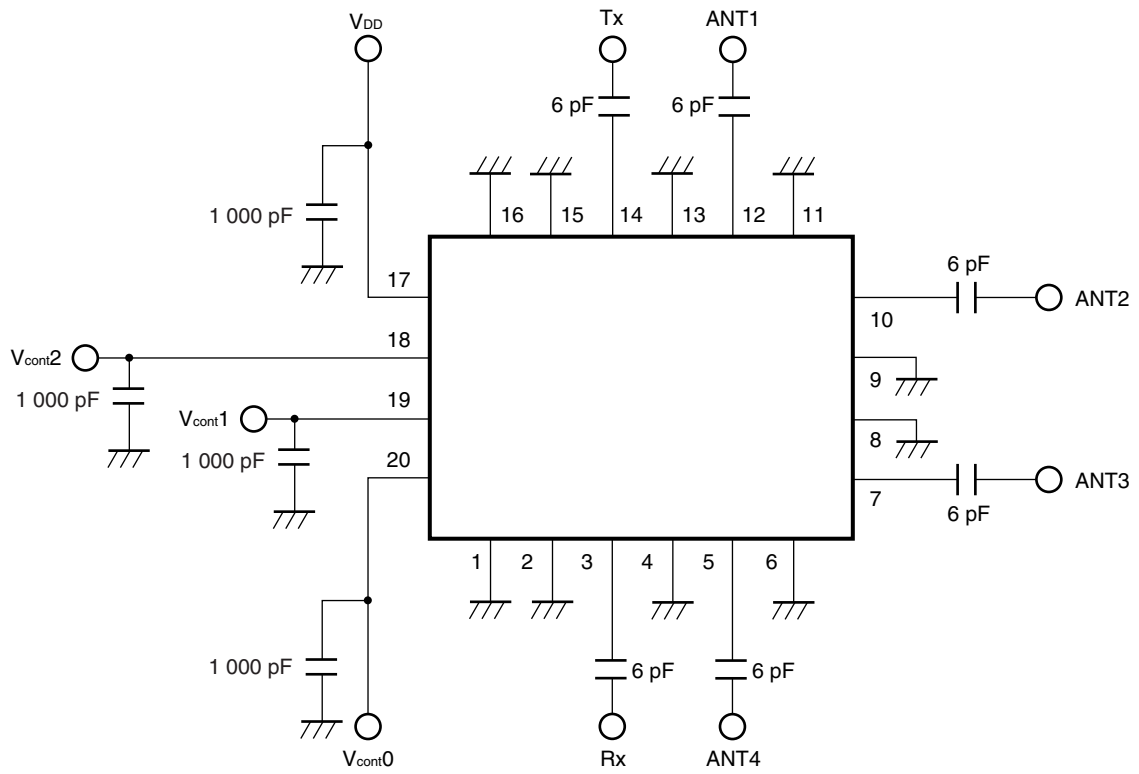

The application circuits and their parameters are for reference only and are not intended for use in actual design-ins.

MOUNTING PAD DIMENSIONS

20-PIN PLASTIC RQFN (UNIT: mm)

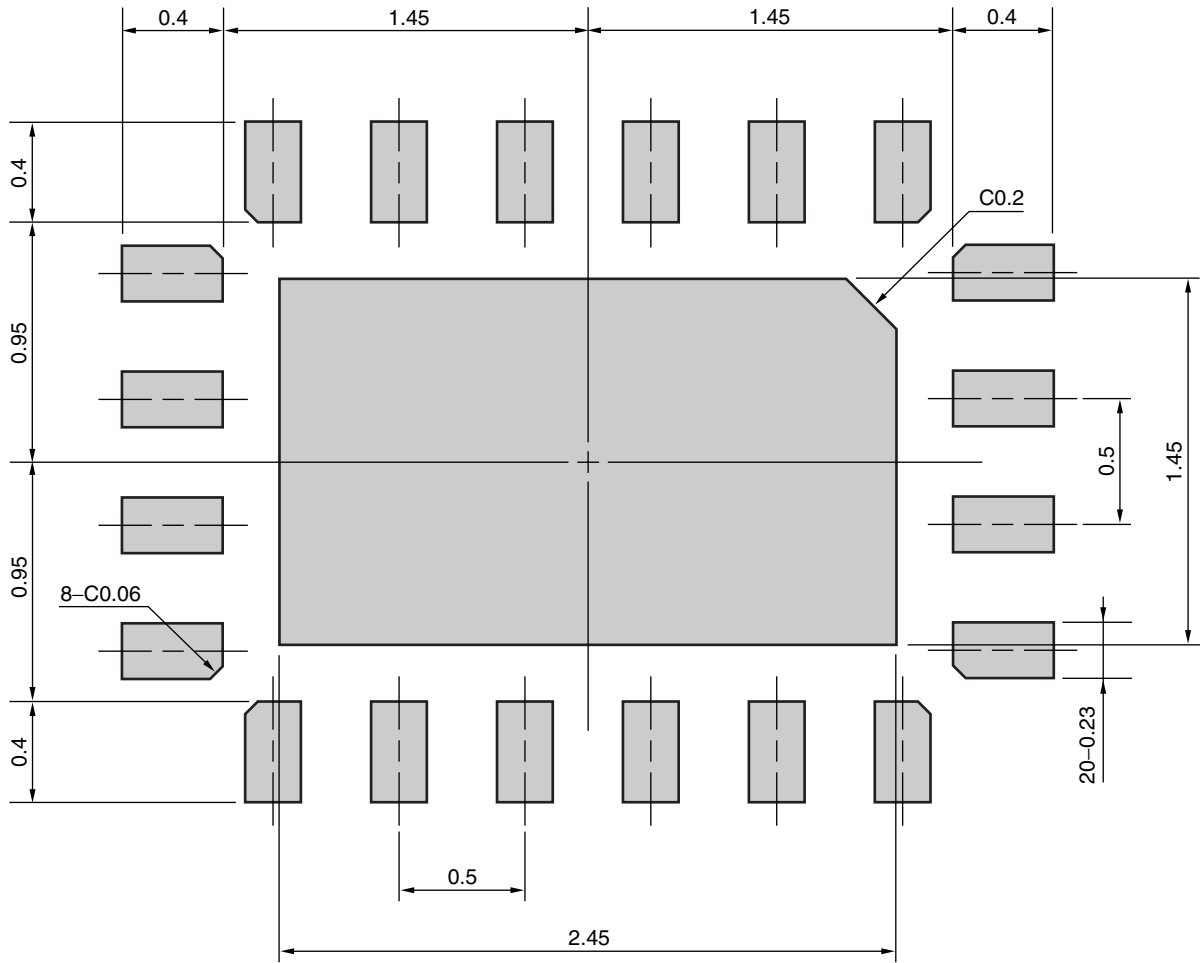

**Remark** The mounting pad layouts in this document are for reference only.

PACKAGE DIMENSIONS

20-PIN PLASTIC RQFN (UNIT: mm)

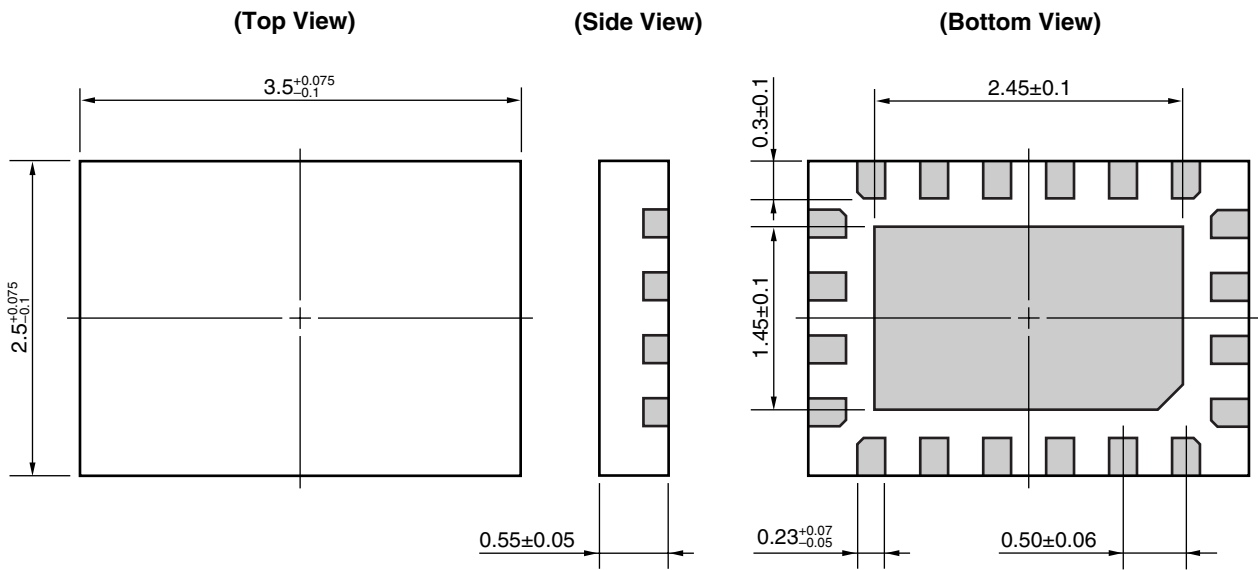

**RECOMMENDED SOLDERING CONDITIONS**

This product should be soldered and mounted under the following recommended conditions. For soldering methods and conditions other than those recommended below, contact your nearby sales office.

Soldering Method	Soldering Conditions	Condition Symbol
Infrared Reflow	Peak temperature (package surface temperature) : 260°C or below Time at peak temperature : 10 seconds or less Time at temperature of 220°C or higher : 60 seconds or less Preheating time at 120 to 180°C : 120±30 seconds Maximum number of reflow processes : 3 times Maximum chlorine content of rosin flux (% mass) : 0.2%(Wt.) or below	IR260
Wave Soldering	Peak temperature (molten solder temperature) : 260°C or below Time at peak temperature : 10 seconds or less Preheating temperature (package surface temperature) : 120°C or below Maximum number of flow processes : 1 time Maximum chlorine content of rosin flux (% mass) : 0.2%(Wt.) or below	WS260
Partial Heating	Peak temperature (terminal temperature) : 350°C or below Soldering time (per side of device) : 3 seconds or less Maximum chlorine content of rosin flux (% mass) : 0.2%(Wt.) or below	HS350

**Caution Do not use different soldering methods together (except for partial heating).**



- **The information in this document is current as of October, 2007. The information is subject to change without notice. For actual design-in, refer to the latest publications of NEC Electronics data sheets or data books, etc., for the most up-to-date specifications of NEC Electronics products. Not all products and/or types are available in every country. Please check with an NEC Electronics sales representative for availability and additional information.**

- No part of this document may be copied or reproduced in any form or by any means without the prior written consent of NEC Electronics. NEC Electronics assumes no responsibility for any errors that may appear in this document.
- NEC Electronics does not assume any liability for infringement of patents, copyrights or other intellectual property rights of third parties by or arising from the use of NEC Electronics products listed in this document or any other liability arising from the use of such products. No license, express, implied or otherwise, is granted under any patents, copyrights or other intellectual property rights of NEC Electronics or others.
- Descriptions of circuits, software and other related information in this document are provided for illustrative purposes in semiconductor product operation and application examples. The incorporation of these circuits, software and information in the design of a customer's equipment shall be done under the full responsibility of the customer. NEC Electronics assumes no responsibility for any losses incurred by customers or third parties arising from the use of these circuits, software and information.
- While NEC Electronics endeavors to enhance the quality, reliability and safety of NEC Electronics products, customers agree and acknowledge that the possibility of defects thereof cannot be eliminated entirely. To minimize risks of damage to property or injury (including death) to persons arising from defects in NEC Electronics products, customers must incorporate sufficient safety measures in their design, such as redundancy, fire-containment and anti-failure features.
- NEC Electronics products are classified into the following three quality grades: "Standard", "Special" and "Specific".

The "Specific" quality grade applies only to NEC Electronics products developed based on a customer-designated "quality assurance program" for a specific application. The recommended applications of an NEC Electronics product depend on its quality grade, as indicated below. Customers must check the quality grade of each NEC Electronics product before using it in a particular application.

"Standard": Computers, office equipment, communications equipment, test and measurement equipment, audio and visual equipment, home electronic appliances, machine tools, personal electronic equipment and industrial robots.

"Special": Transportation equipment (automobiles, trains, ships, etc.), traffic control systems, anti-disaster systems, anti-crime systems, safety equipment and medical equipment (not specifically designed for life support).

"Specific": Aircraft, aerospace equipment, submersible repeaters, nuclear reactor control systems, life support systems and medical equipment for life support, etc.

The quality grade of NEC Electronics products is "Standard" unless otherwise expressly specified in NEC Electronics data sheets or data books, etc. If customers wish to use NEC Electronics products in applications not intended by NEC Electronics, they must contact an NEC Electronics sales representative in advance to determine NEC Electronics' willingness to support a given application.

(Note)

- (1) "NEC Electronics" as used in this statement means NEC Electronics Corporation and also includes its majority-owned subsidiaries.
- (2) "NEC Electronics products" means any product developed or manufactured by or for NEC Electronics (as defined above).

<p><b>Caution</b> GaAs Products</p>	<p>This product uses gallium arsenide (GaAs). GaAs vapor and powder are hazardous to human health if inhaled or ingested, so please observe the following points.</p> <ul style="list-style-type: none"> <li>• Follow related laws and ordinances when disposing of the product. If there are no applicable laws and/or ordinances, dispose of the product as recommended below.             <ol style="list-style-type: none"> <li>1. Commission a disposal company able to (with a license to) collect, transport and dispose of materials that contain arsenic and other such industrial waste materials.</li> <li>2. Exclude the product from general industrial waste and household garbage, and ensure that the product is controlled (as industrial waste subject to special control) up until final disposal.</li> </ol> </li> <li>• Do not burn, destroy, cut, crush, or chemically dissolve the product.</li> <li>• Do not lick the product or in any way allow it to enter the mouth.</li> </ul>
-------------------------------------	---