

Features

- Low Cost
- 10mW Output Power
- Gold Plated Solder Pins
- Detects Direction of Motion
- Rugged Die cast Construction
- 10Hz - 5000Hz IF Bandwidth
- Lead Free (RoHS* Compliant)

Description and Applications

M/A-COM's MACS-007802-0M1R10 is a RoHS Compliant K-Band Stereo Doppler transceiver consisting of a Gunn Diode oscillator and two Schottky Diode mixers assembled into a die cast waveguide package. These Transceivers are well suited for high volume applications where small size and reliability are required. Typical applications include automatic door openers, police radar and presence sensing applications, where Direction of motion is required.

Product Specifications

| Parameter | Test Conditions | Units | Min. | Typ. | Max. |
|-------------------------|-----------------|-------------|--------|--------|--------|
| Operating Frequency | +25 °C | GHz | 24.100 | 24.125 | 24.150 |
| Output Power | +25 °C | mW | 10.0 | | |
| Operating Current | +25 °C | mA | 140 | 175 | 200 |
| Operating Voltage | +25 °C | VDC | | 5.0 | |
| Schottky Diode Noise | +25 °C | micro-Volts | | 2.5 | 5.0 |
| Transceiver Sensitivity | +25 °C | -dBc | -90 | -103 | |
| Mixer Phasing | +25 °C | Degrees | 50 | | 120 |

Operating temperature to full specification -30°C to +70°C

Absolute Maximum Ratings¹

| Parameter | Maximum Ratings |
|-------------------------|-------------------|
| Operating Temperature | -40 °C to +85 °C |
| Storage Temperature | -65 °C to +150 °C |
| Incident RF Input Power | +20 dBm |
| DC Input (Gunn Diode) | +5.5VDC |
| Soldering Temperature | +260 °C max. |

1. Exceeding these limits may cause permanent damage.

Note: Device is ESD Sensitive. Proper ESD Precautions should be used when handling this Device..

Package Outline



PIN Configuration

| PIN | Function |
|-----|---------------------|
| 1 | DC Input |
| 2 | GND |
| 3 | IF Output (Mixer 1) |
| 4 | IF Output (Mixer 2) |

Functional Block Diagram

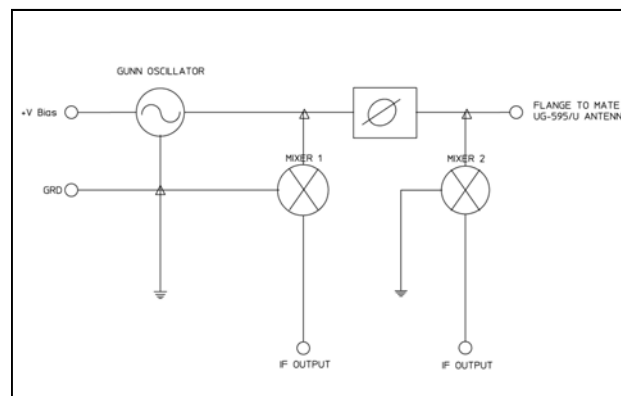

*Restrictions on Hazardous Substances, European Union Directive 2002/95/EC.

ADVANCED: Data Sheets contain information regarding a product MA-COM Technical Solutions is considering for development. Performance is based on target specifications, simulated results, and/or prototype measurements. Commitment to develop is not guaranteed.
PRELIMINARY: Data Sheets contain information regarding a product MA-COM Technical Solutions has under development. Performance is based on engineering tests. Specifications are typical. Mechanical outline has been fixed. Engineering samples and/or test data may be available. Commitment to produce in volume is not guaranteed.

• **North America** Tel: 800.366.2266 / Fax: 978.366.2266
 • **Europe** Tel: 44.1908.574.200 / Fax: 44.1908.574.300
 • **Asia/Pacific** Tel: 81.44.844.8296 / Fax: 81.44.844.8298
 Visit www.macom.com for additional data sheets and product information.

MA-COM Technical Solutions and its affiliates reserve the right to make changes to the product(s) or information contained herein without notice.

MACS-007802-0M1R10



Stereo Doppler Transceiver
24.125 GHz

M/A-COM Products
Rev. -

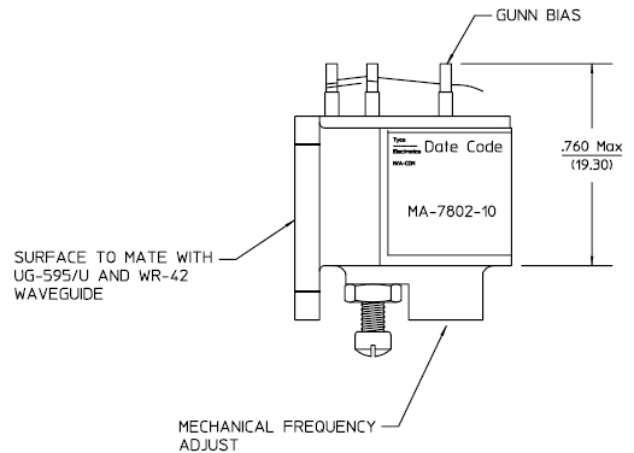
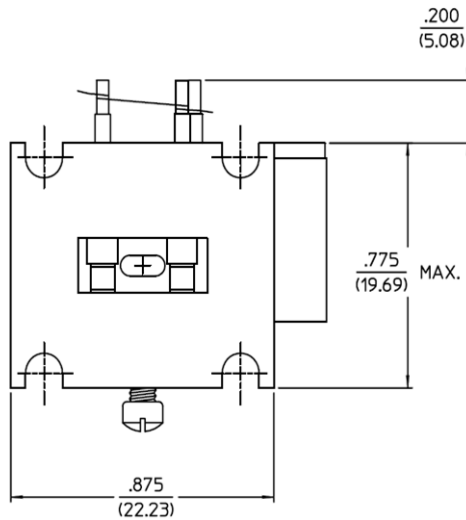
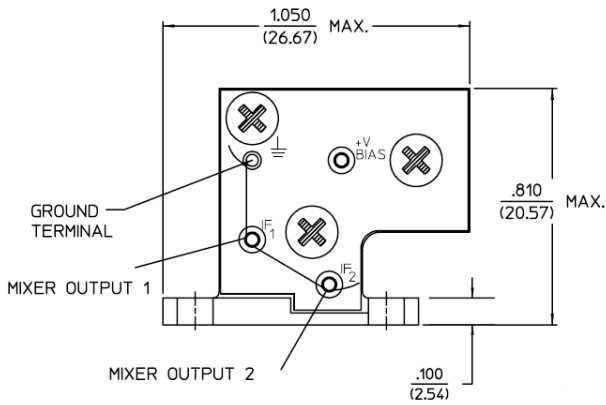

ADVANCED: Data Sheets contain information regarding a product MA-COM Technical Solutions is considering for development. Performance is based on target specifications, simulated results, and/or prototype measurements. Commitment to develop is not guaranteed.
PRELIMINARY: Data Sheets contain information regarding a product MA-COM Technical Solutions has under development. Performance is based on engineering tests. Specifications are typical. Mechanical outline has been fixed. Engineering samples and/or test data may be available. Commitment to produce in volume is not guaranteed.

- **North America** Tel: 800.366.2266 / Fax: 978.366.2266
 - **Europe** Tel: 44.1908.574.200 / Fax: 44.1908.574.300
 - **Asia/Pacific** Tel: 81.44.844.8296 / Fax: 81.44.844.8298
- Visit www.macom.com for additional data sheets and product information.

MA-COM Technical Solutions and its affiliates reserve the right to make changes to the product(s) or information contained herein without notice.