

7.5-22.5/15.0-45.0 GHz Active Doubler QFN, 3x3 mm

Mimix
BROADBAND™

April 2008 - Rev 19-Apr-08

XX1000-QT
RoHS

Features

- ✕ +18 dBm Output Power
- ✕ -20 dBc Fundamental Leakage
- ✕ 3x3 mm QFN Package
- ✕ RoHS Compliant
- ✕ 100% RF, DC and Output Power Testing



General Description

Mimix Broadband's 7.5-22.5/15.0-45.0 GHz SMD active doubler delivers + 18 dBm of output power. The device combines an active doubler with an output buffer amplifier that delivers constant power over a range of input powers. The device has excellent rejection of the fundamental and harmonic products and requires a single positive bias supply. This device uses Mimix Broadband's 0.15 GaAs pHEMT device model technology to ensure high reliability and uniformity. The device comes in a low-cost 3x3mm QFN Surface Mount Plastic Package offering excellent RF and thermal properties and is RoHS compliant. This device is well suited for Point-to-Point Radio, Microwave, LMDS, SATCOM and VSAT applications.

Absolute Maximum Ratings

Supply Voltage (Vd)	+6.0 VDC
Supply Voltage (Vss)	-6.0 VDC
Supply Current (Id)	300 mA
Supply Current (Iss)	60 mA
Gate Bias Voltage (Vg)	-0.4 VDC
Input Power (RF Pin)	+15.0 dBm
Storage Temperature (Tstg)	-65 to +165 °C
Operating Temperature (Ta)	-55 to MTTF Table ¹
Channel Temperature (Tch)	MTTF Table ¹

(1) Channel temperature affects a device's MTTF. It is recommended to keep channel temperature as low as possible for maximum life.

Electrical Characteristics (Ambient Temperature T = 25 °C)

Parameter	Units	Min.	Typ.	Max.
Input Frequency Range (fin)	GHz	7.5	-	22.5
Output Frequency Range (fout)	GHz	15.0	-	45.0
Input Return Loss (S11)	dB	-	15.0	-
Output Return Loss (S22)	dB	-	7.0	-
Saturated Output Power (Psat)	dBm	-	+18	-
RF Input Power (RF Pin)	dBm	-10.0	-	+10.0
Fundamental Leakage (fin)	dBc	-	20	-
Third Harmonic Leakage (3xfin)	dBc	-	30	-
Fourth Harmonic Leakage (4xfin)	dBc	-	10	-
Drain Bias Voltage (Vd1,2)	VDC	-	+5.0	+5.5
Gate Bias Voltage (Vg1)	VDC	-0.8	-0.6	-0.4
Gate Bias Voltage (Vg2)	VDC	-1.2	0.0	+0.1
Supply Current (Id1,2) (Vd=5.0V, Vg1=-0.6V, Vg2=0.0V Typical)	mA	-	220	250
Source Voltage (Vss)	VDC	-5.5	-5.0	-2.0
Source Current (Iss)	mA	25	50	60

7.5-22.5/15.0-45.0 GHz Active Doubler QFN, 3x3 mm

Doubler Measurements, Nominal Bias Conditions

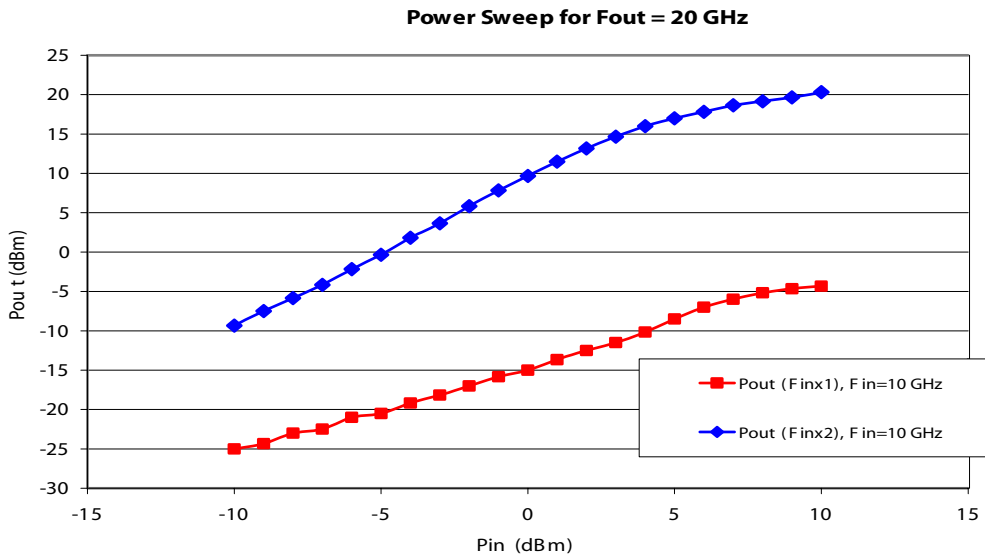
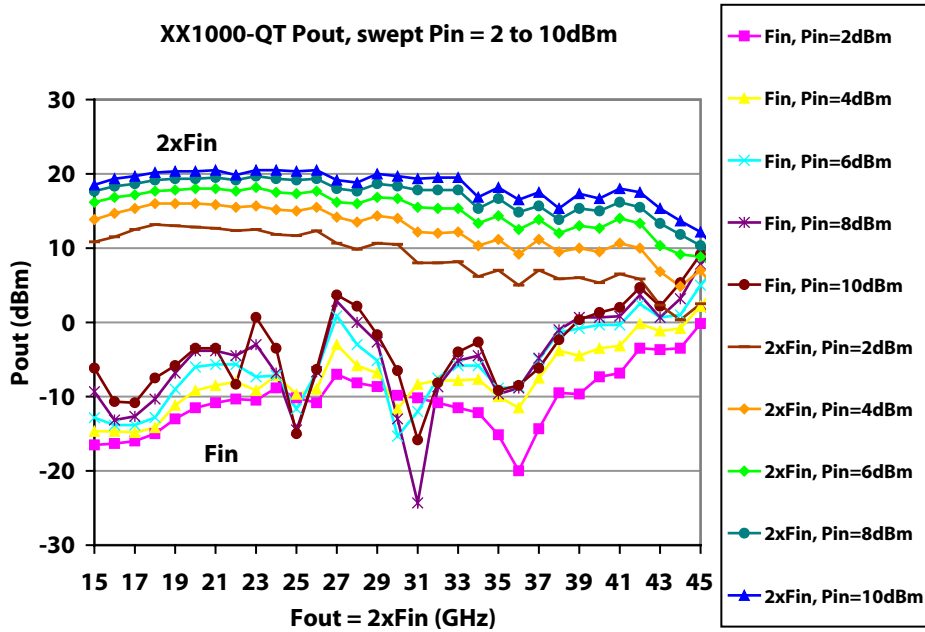

Measured results taken at room temperature in 40 GHz connectorized test fixture with no de-embedding.

7.5-22.5/15.0-45.0 GHz Active Doubler QFN, 3x3 mm



April 2008 - Rev 19-Apr-08

XX1000-QT
RoHS

Doubler Measurements (cont.)

XX1000-QT, Pout vs Temp. Pin = 0 dBm

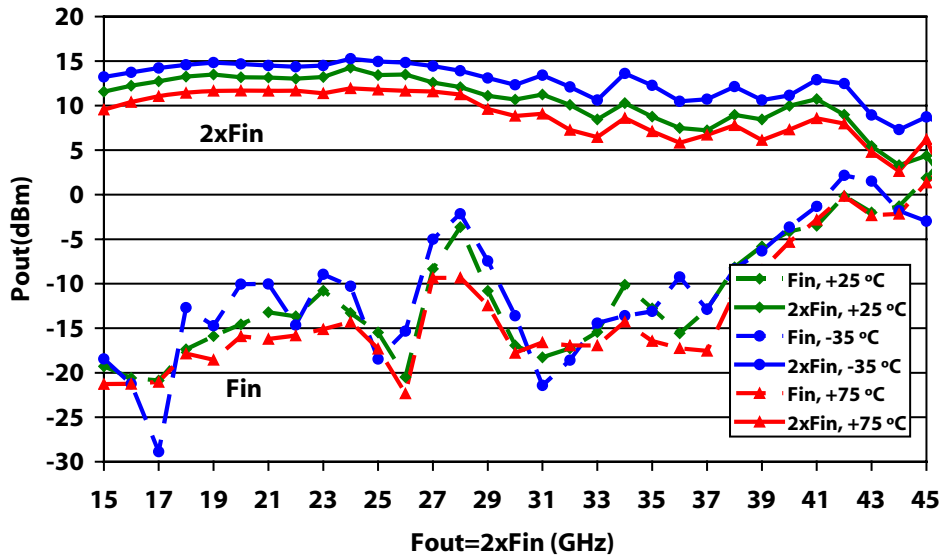

XX1000-QT, Pout vs Temp. Pin = 5 dBm

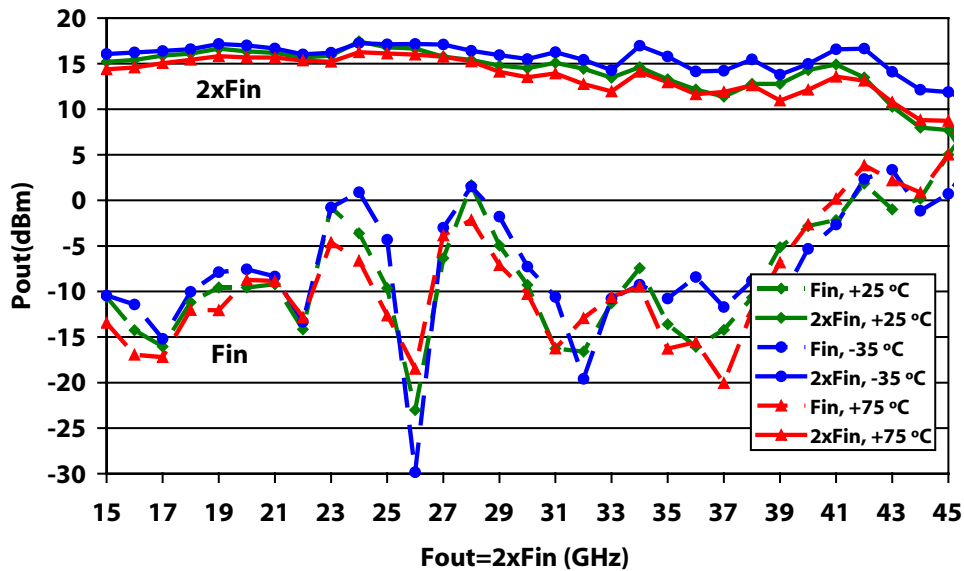

7.5-22.5/15.0-45.0 GHz Active Doubler QFN, 3x3 mm

Doubler Measurements (cont.)

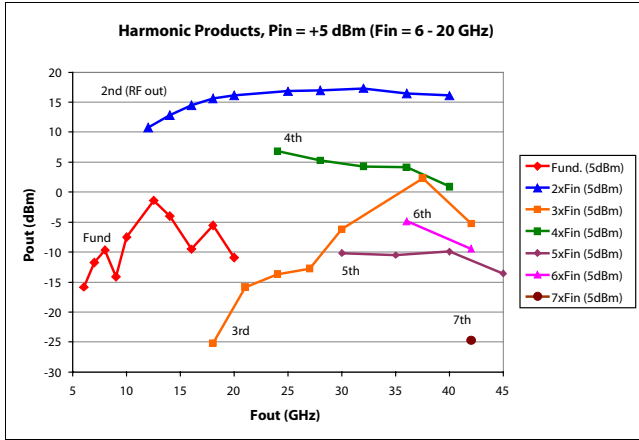

* Measured on-wafer with pre-packaging.

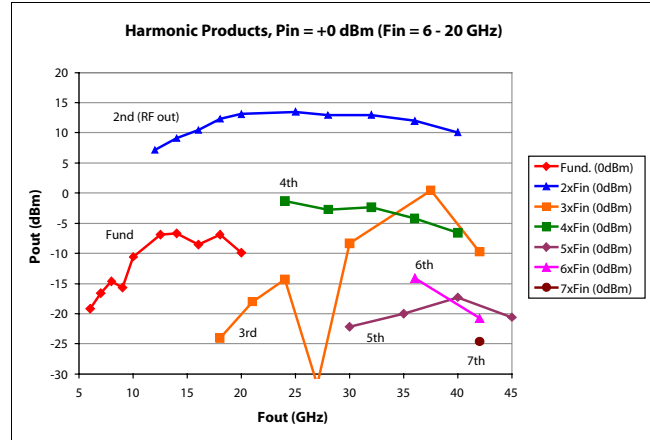

* Measured on-wafer with pre-packaging.



7.5-22.5/15.0-45.0 GHz Active Doubler QFN, 3x3 mm

April 2008 - Rev 19-Apr-08

Physical Dimensions

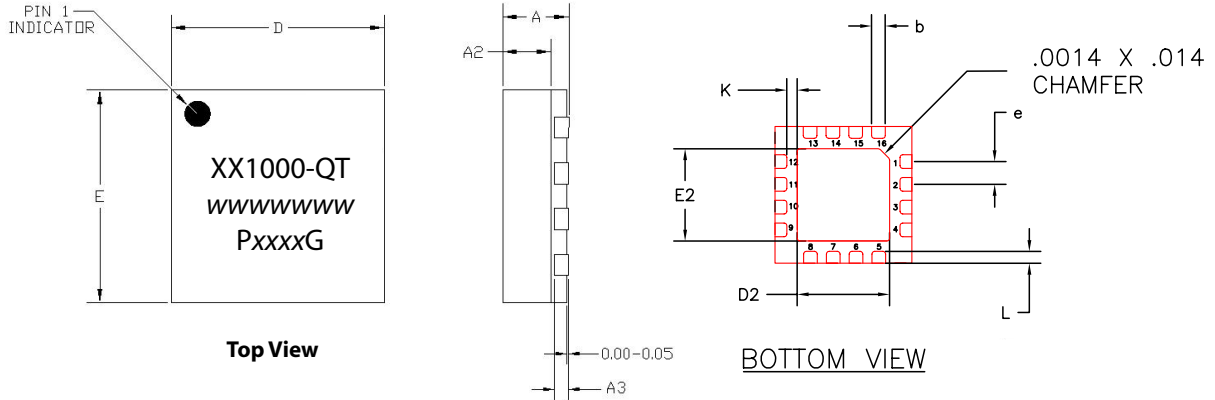

RECOMMENDED SOLDER PAD PITCH AND DIMENSIONS

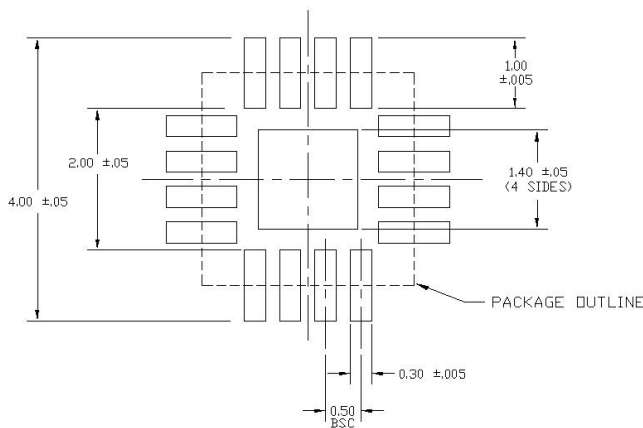

NOTE:
1. ALL DIMENSIONS ARE IN mm

	MIN	NDM	MAX
A	0.80	0.90	1.00
A3	0.20 REF		
A2	0	0.65	1.00
b	0.20	0.25	0.30
K	0.20	-	-
D	3.00 BSC		
E	3.00 BSC		
e	0.50		
D2	1.50	1.65	1.80
E2	1.50	1.65	1.80
L	0.16	0.26	0.36

Functional Schematic

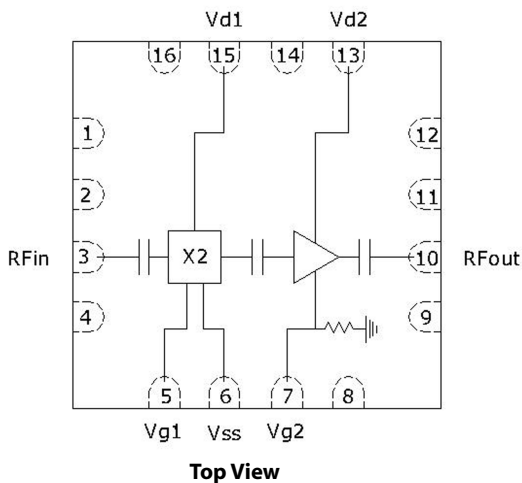

Pin Designation

Pin Number	Function	Typ. Value	Units
3	RF IN	-10 to +10	dBm
5	VG1	-0.6	V
6	VSS	-5	V
7	VG2	0.0 or GND ¹	V
10	RF OUT	+17	dBm
13	VD2	+5.0	V
15	VD1	+5.0	V
2, 4, 9, 11	GND		
8, 12, 14, 16	N/C		

¹ VG2 can be used for current regulating VD2 or VG2 can be set to GND with VD2 self-biasing at approximately 140mA.

7.5-22.5/15.0-45.0 GHz Active Doubler QFN, 3x3 mm

App Note [1] Biasing - It is recommended to separately bias each doubler stage with fixed voltages of $V_{d(1,2)}=5.0V$, $V_{ss}=-5.0V$ and $V_{g1}=-0.6V$. The typical DC currents are $I_{d1}=80mA$, $I_{d2}=140mA$ and $I_{ss}=50mA$. V_{g2} can be used for active control biasing of V_{d2} , or it can be set to GND and V_{d2} will self bias at approximately 140mA. Maximum output power is achieved with $V_{ss}=-5.0V$ and $I_{ss}=50mA$ but the device will operate with reduced bias to $V_{ss}=-2.0V$ and $I_{ss}=25mA$. It is also recommended to use active biasing on V_{d2} with V_{g2} to keep the currents constant as the RF power and temperature vary; this gives the most reproducible results. Depending on the supply voltage available and the power dissipation constraints, the bias circuit may be a single transistor or a low power operational amplifier, with a low value resistor in series with the drain supply used to sense the current. The gate of the pHEMT is controlled to maintain correct drain current and thus drain voltage. The typical gate voltage for $V_{g2}=-0.1V$. Typically the gate is protected with Silicon diodes to limit the applied voltage. Also, make sure to sequence the applied voltage to ensure negative gate bias is available before applying the positive drain supply.

MTTF

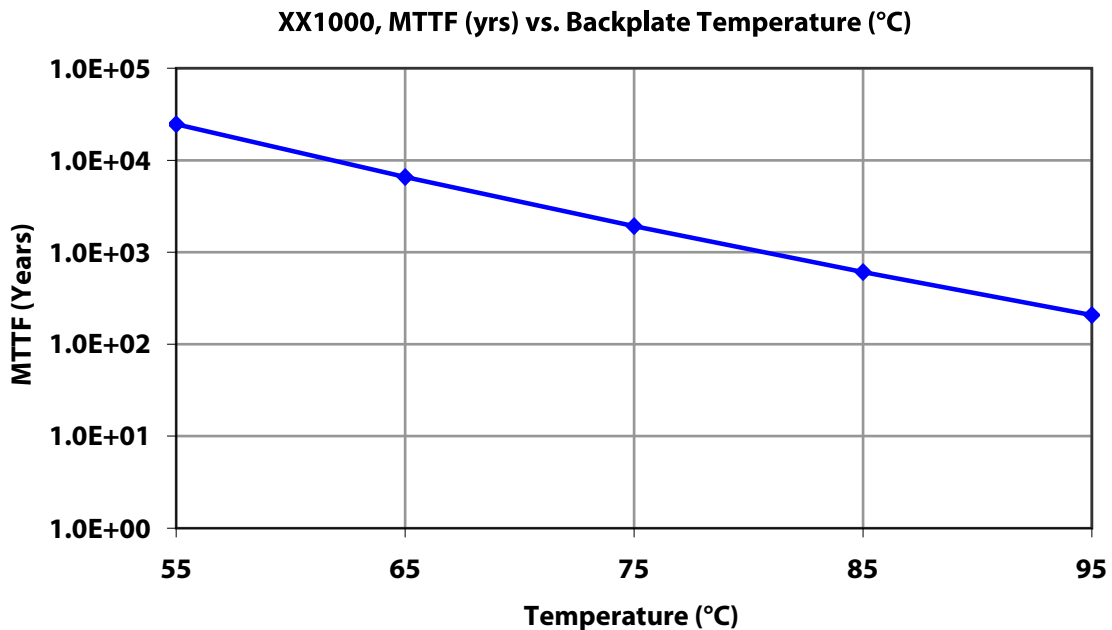

MTTF is calculated from accelerated life-time data of single devices and assumes isothermal back-plate.

Bias Conditions: $V_{d1,2} = 5.0V$, $I_{d1,2} = 220 mA$, $V_{ss} = -5.0V$, $I_{ss} = 50 mA$

7.5-22.5/15.0-45.0 GHz Active Doubler QFN, 3x3 mm

PCB Layout

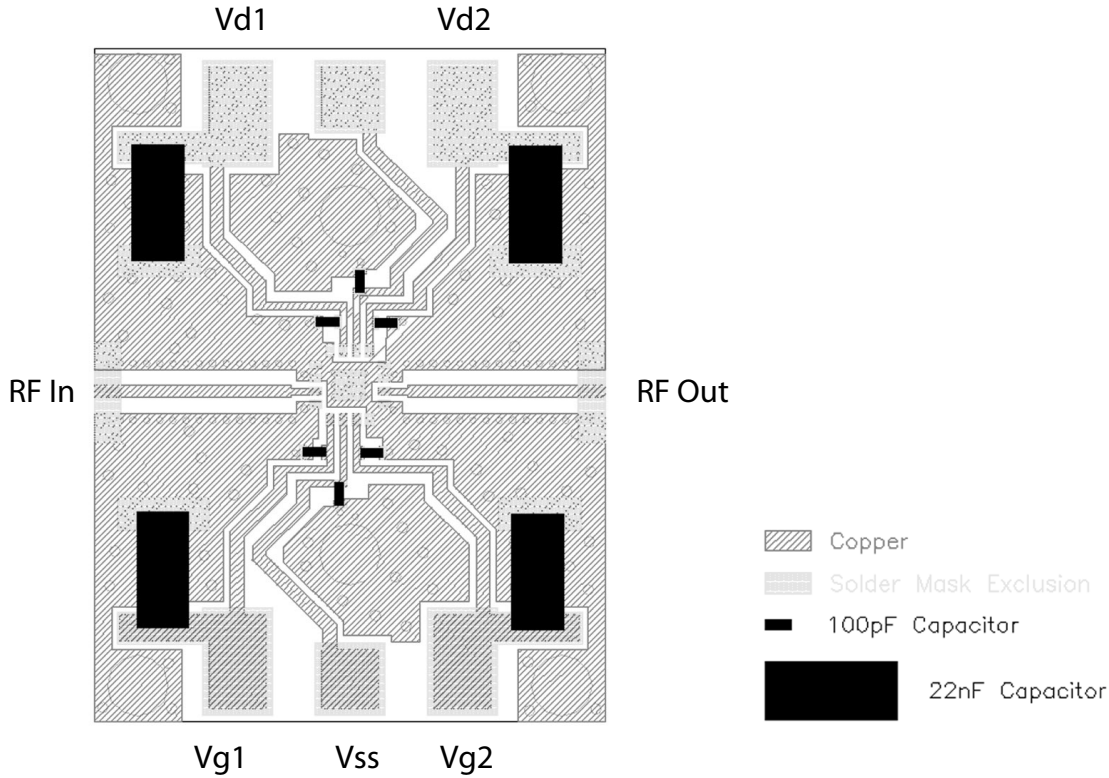

Application Circuit

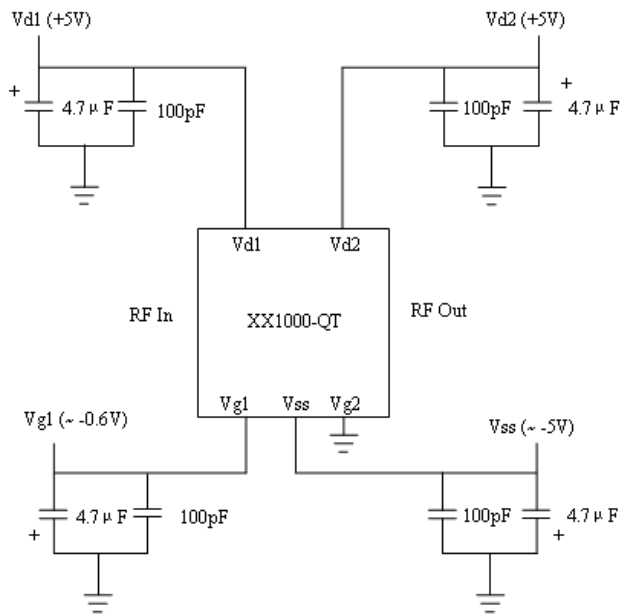

7.5-22.5/15.0-45.0 GHz Active Doubler QFN, 3x3 mm

April 2008 - Rev 19-Apr-08

Handling and Assembly Information

CAUTION! - Mimix Broadband MMIC Products contain gallium arsenide (GaAs) which can be hazardous to the human body and the environment. For safety, observe the following procedures:

- Do not ingest.
- Do not alter the form of this product into a gas, powder, or liquid through burning, crushing, or chemical processing as these by-products are dangerous to the human body if inhaled, ingested, or swallowed.
- Observe government laws and company regulations when discarding this product. This product must be discarded in accordance with methods specified by applicable hazardous waste procedures.

Life Support Policy - Mimix Broadband's products are not authorized for use as critical components in life support devices or systems without the express written approval of the President and General Counsel of Mimix Broadband. As used herein: (1) Life support devices or systems are devices or systems which, (a) are intended for surgical implant into the body, or (b) support or sustain life, and whose failure to perform when properly used in accordance with instructions for use provided in the labeling, can be reasonably expected to result in a significant injury to the user. (2) A critical component is any component of a life support device or system whose failure to perform can be reasonably expected to cause the failure of the life support device or system, or to affect its safety or effectiveness.

Package Attachment - This packaged product from Mimix Broadband is provided as a rugged surface mount package compatible with high volume solder installation. The package is a low-cost plastic package. Vacuum tools or other suitable pick and place equipment may be used to pick and place this part. Care should be taken to ensure that there are no voids or gaps in the solder connection so that good RF, DC and ground connections are maintained. Voids or gaps can eventually lead not only to RF performance degradation, but reduced reliability and life of the product due to thermal stress.

Typical Reflow Profiles

Reflow Profile	SnPb	Pb Free
Ramp Up Rate	3-4 °C/sec	3-4 °C/sec
Activation Time and Temperature	60-120 sec @ 140-160 °C	60-180 sec @ 170-200 °C
Time Above Melting Point	60-150 sec	60-150 sec
Max Peak Temperature	240 °C	265 °C
Time Within 5 °C of Peak	10-20 sec	10-20 sec
Ramp Down Rate	4-6 °C/sec	4-6 °C/sec

Mimix Lead-Free RoHS Compliant Program - Mimix has an active program in place to meet customer and governmental requirements for eliminating lead (Pb) and other environmentally hazardous materials from our products. All Mimix RoHS compliant components are form, fit and functional replacements for their non-RoHS equivalents. Lead plating of our RoHS compliant parts is 100% matte tin (Sn) over copper alloy and is backwards compatible with current standard SnPb low-temperature reflow processes as well as higher temperature (260°C reflow) "Pb Free" processes.

Part Number for Ordering

XX1000-QT-0G00
XX1000-QT-0G0T
XX1000-QT-EV1

Description

Matte Tin plated RoHS compliant QFN 3x3 16L surface mount package in bulk quantity
Matte Tin plated RoHS compliant QFN 3x3 16L surface mount package in tape and reel
XX1000-QT Evaluation Board

We also offer this part with alternative plating. Please contact your regional sales manager for more information regarding different plating types.



Proper ESD procedures should be followed when handling this device.

Mimix Broadband, Inc., 10795 Rockley Rd., Houston, Texas 77099
Tel: 281.988.4600 Fax: 281.988.4615 mimixbroadband.com

Page 8 of 8