

## CUSTOM BONDED FIN HEAT SINKS AND ASSEMBLIES



Wakefield Engineering offers an extensive line of natural convection and forced convection custom bonded fin heat sinks assemblies. Configurable in a variety of ways, they are reliable, cost effective, and highly efficient thermal management solutions for high power and densely packaged applications, even in demanding shock and vibration environments.

### MECHANICAL DIMENSIONS

**MOUNTING LEG  
(EXTRUSION PROFILE 8930)  
(EXTRUSION PROFILE 8120)**

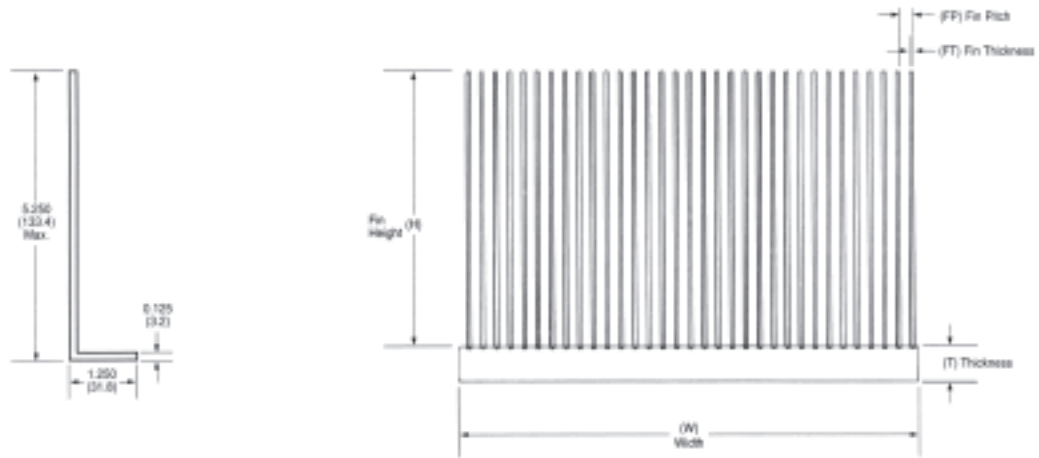

Dimensions: in. (mm)

BONDED FIN BASES						Thermal Resistance °C/W			
Base Extrusion Profile No.	W	T	FT	FP	Max # Fins	Natural Convection		Forced Convection	
						H = 2"	H = 4"	H = 2"	H = 4"
8711	2.800 (71.1)	0.520 (13.2)	.050 (1.3)	0.275 (5.4)	10	1.360	0.830	0.459	0.277
8731	3.615 (91.8)	0.575 (14.6)	.050 (1.3)	0.239 (6.1)	15	1.110	0.685	0.281	0.168
8546	4.000 (101.6)	0.500 (12.7)	.050 (1.3)	0.200 (5.1)	20	1.330	0.823	0.215	0.144
8737	4.425 (112.4)	0.650 (16.5)	.050 (1.3)	0.238 (6.0)	18	0.937	0.580	0.233	0.140
8119	4.750 (120.7)	0.500 (12.7)	.050 (1.3)	0.288 (7.3)	16	0.880	0.539	0.222	0.157
8712	5.000 (127.0)	0.530 (13.5)	.050 (1.3)	0.198 (5.0)	25	1.122	0.692	0.170	0.101
8732	5.650 (143.5)	0.500 (12.7)	.050 (1.3)	0.200 (5.1)	28	1.011	0.625	0.152	0.090
8556	6.000 (152.4)	0.500 (12.7)	.050 (1.3)	0.250 (6.4)	24	0.751	0.438	0.153	0.107
8542	6.620 (168.1)	0.500 (12.7)	.050 (1.3)	0.200 (5.1)	33	0.880	0.519	0.122	0.082
8671	7.230 (183.6)	0.550 (14.0)	.050 (1.3)	0.239 (6.1)	30	0.655	0.399	0.123	0.086
8823	7.440 (189.0)	0.525 (13.3)	.050 (1.3)	0.200 (5.1)	37	0.820	0.500	0.118	0.070
8734	7.500 (190.5)	0.560 (14.2)	.050 (1.3)	0.400 (10.2)	19	0.550	0.310	0.213	0.130
8545	8.000 (203.2)	0.500 (12.7)	.050 (1.3)	0.200 (5.1)	40	0.591	0.353	0.095	0.053
8709	8.327 (211.5)	0.400 (10.2)	.050 (1.3)	0.215 (5.5)	37	0.507	0.310	0.081	0.048
8715	8.780 (223.0)	0.600 (15.2)	.050 (1.3)	0.270 (6.9)	28	0.384	0.231	0.106	0.063
8707	10.00 (254.0)	0.550 (14.0)	.050 (1.3)	0.238 (6.0)	42	0.361	0.220	0.071	0.042
8121	10.78 (273.8)	0.560 (14.2)	.050 (1.3)	0.238 (6.0)	45	0.348	0.209	0.065	0.040
8733	12.60 (320.0)	0.600 (15.2)	.050 (1.3)	0.207 (5.3)	60	0.383	0.235	0.075	0.030
8714	14.00 (355.6)	0.525 (13.3)	.050 (1.3)	0.250 (6.4)	56	0.275	0.168	0.053	0.032
8735	15.00 (381.0)	0.625 (15.9)	.050 (1.3)	0.250 (6.4)	60	0.264	0.161	0.049	0.030

Contact Wakefield Thermal Solutions for additional standard profile options at 603-635-2800 / sales@wakefield.com

- Notes:
1. Natural and forced convection thermal resistances based on 6.000 in. length for profiles less than 8.000" wide.
  2. Natural and forced convection thermal resistances based on 12.000 in. length for profiles 8.000" wide and greater
  3. Forced convection thermal resistance based on 500 LFM, shrouded, horizontal, distributed heat load.
  4. Forced convection bonded fin assemblies use standard "muffin" fans.
  5. Dimensions shown are as extruded. To improve flatness across the width, bases can be machined. Machined base thickness will be reduced.

### ORDER GUIDE - EXAMPLE

Example Part Number - BE8546-1200-U4W

- BE8546 = Bonded fin base extrusion profile identifier
- Length (inches; 12.00 shown, two decimal point assumed)
- Finish (G = Gold Chromate, U = Unfinished)
- Fin Height (4 inches shown)
- Mounting Options (L = Mounting Legs, W = No Mounting Legs)

### PART NUMBERING ORDER GUIDE\*

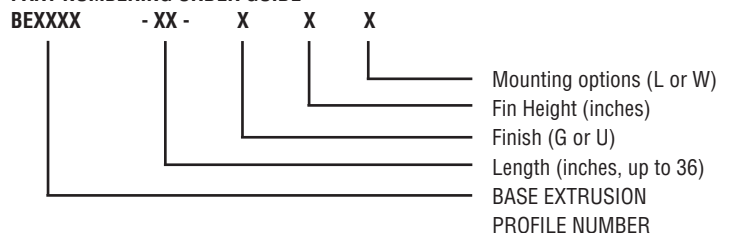

## maxiTHERM-HD<sup>3</sup>™ BONDED FIN FORCED CONVECTION SERIES #1

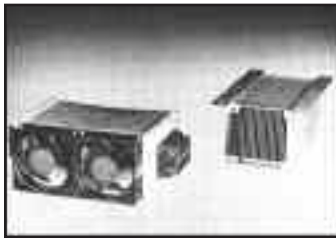

maxiTHERM-HD<sup>3</sup>™ Bonded Fin Forced Convection Series #1 heat sinks provide more effective cooling per cubic inch of space compared to extruded heat sinks. Exceptionally low thermal resistance values in forced convection applications are achieved with “Series #1” models, as low as 0.024°C/W for a double unit employing 2 fans. Mounting hole pattern is 4.125 in. sq. for standard 120 mm axial (“box”) fans. These heat sinks are ideal for a variety of high power applications, even in the most demanding shock and vibration environments.

### SERIES #1 (5.25” TALL ASSEMBLY)

maxiTHERM-HD <sup>3</sup> ™ Package Series #1	Standard Muffin Fan (S)	Dimension (in inches)			Perimeter (in inches)	Thermal Resistance °C/W
		“A”	“B”	“C”		
1A	1	7.000 (177.8)	2.500 (63.5)	4.500 (114.3)	742.5 (18859.5)	0.10
1B	1	9.500 (241.3)	3.750 (95.3)	7.000 (114.3)	1515.0 (38481.0)	0.09
1C	1	12.000 (304.8)	5.000 (127.0)	9.500 (114.3)	1567.5 (39814.5)	0.07
1D	1	14.500 (368.3)	6.250 (158.8)	12.000 (114.3)	1980.5 (50304.7)	0.05
1E	2	14.590 (370.6)	6.000 (152.4)	12.000 (114.3)	4536.0 (115214.4)	0.028
1F	2	16.590 (429.0)	7.000 (177.8)	14.000 (114.3)	5292.0 (134416.8)	0.025
1G	2	18.590 (472.2)	8.000 (203.2)	16.000 (114.3)	60.48.0 (153619.2)	0.024

Refer to the following page for ordering information.

1Z	NON-STANDARD LENGTH
ZZ	NON-STANDARD CONFIGURATION & LENGTH

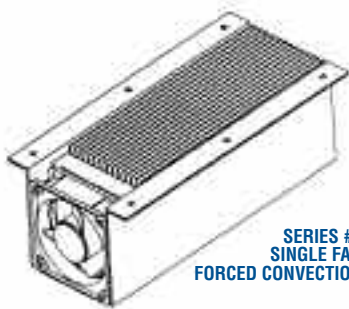

SERIES #1 SINGLE FAN FORCED CONVECTION

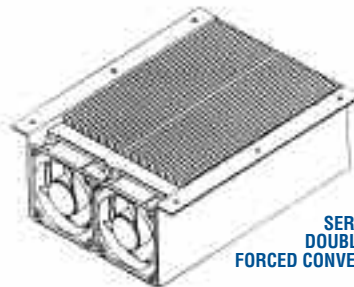

SERIES #1 DOUBLE FAN FORCED CONVECTION

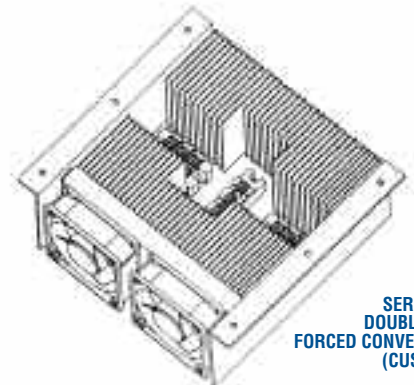

SERIES #1 DOUBLE FAN FORCED CONVECTION (CUSTOM)

### MECHANICAL DIMENSIONS

#### SERIES #1 SINGLE FAN FORCED CONVECTION

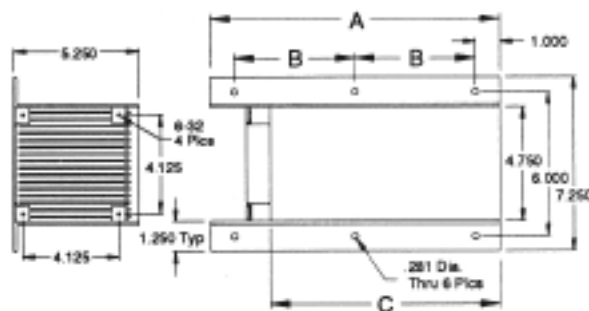

#### SERIES #1 DOUBLE FAN FORCED CONVECTION

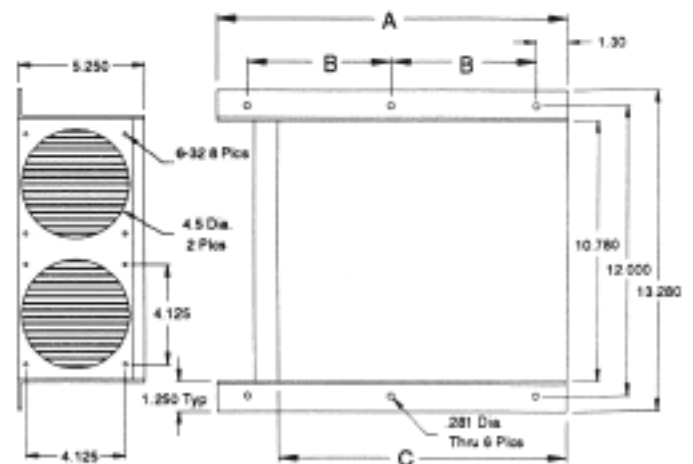

**Notes:**

1. Standard muffin fans not included, order separately.

## maxiTHERM-HD<sup>3™</sup> BONDED FIN FORCED CONVECTION SERIES #2



maxiTHERM-HD<sup>3™</sup> Bonded Fin Natural Convection Series #2 heat sinks are designed for a variety of high power applications. These heat sinks are ideal even in the most demanding shock and vibration environments. Standard heat sink lengths range from 7.000 in. (177.8 mm) to 18.590 in. (472.2 mm) and the overall height is 3.130 in. (79.5 mm). Custom lengths, mounting options, and other configurations can be accommodated.

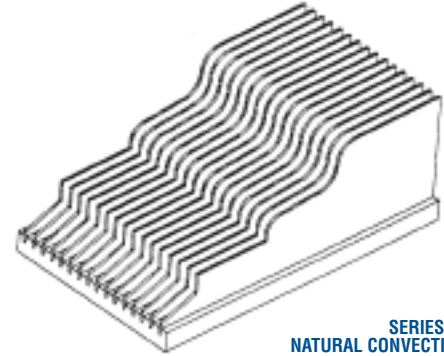

SERIES #2  
NATURAL CONVECTION  
(CUSTOM)

### SERIES #2 (3.13" TALL ASSEMBLY)

maxiTHERM-HD <sup>3™</sup> Package Series #1	Dimension (in inches)		Perimeter (in inches)	Thermal Resistance °C/W
	"A"	"B"		
2A	4.500 (114.3)	1.250 (31.8)	427.5 (10858.5)	0.41**
2B	9.500 (177.8)	2.500 (63.5)	665.0 (16891.0)	0.38**
2C	9.500 (241.3)	3.750 (95.3)	902.0 (22910.8)	0.35**
2D	12.000 (304.8)	5.000 (127.0)	1140.0 (28956.0)	0.33**

2Z	NON-STANDARD LENGTH
ZZ	NON-STANDARD CONFIGURATION & LENGTH

### SERIES #2 NATURAL CONVECTION

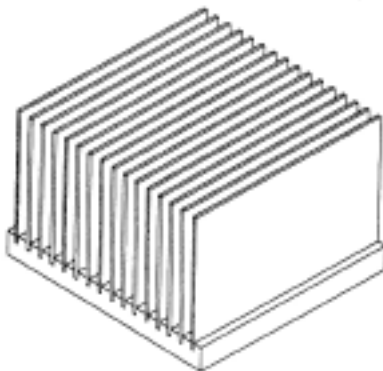

### MECHANICAL DIMENSIONS

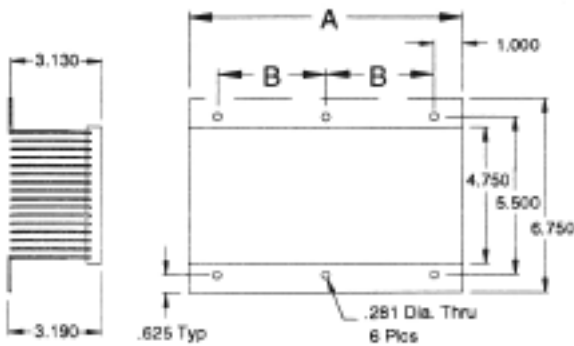

### ORDERING INFORMATION

BE8-	+	+	+	+	MODIFIER
					NNNN Factory issued number for modification to customer requirements.
					PLATING OPTIONS
					GI Gold Iridite
					CI Clear Iridite
					N No Plating (Wash & Etch)
					MOUNTING OPTIONS
					L Mounting Legs
					F Fan Brackets & Mounting Legs (series #1 only)
					W No Brackets or Legs
					PACKAGE LENGTH ("A" Dimension)
					SERIES #1 (5.25" tall assembly)
					PN LENGTH
					1A 7.000"
					1B 9.500"
					1C 12.000"
					1D 14.500"
					1E 14.590"
					1F 18.590"
					1G 18.590"
					1Z non-standard lengths (Note 2)
					ZZ non-standard configuration & length
					PACKAGE LENGTH ("A" Dimension)
					SERIES #2 (3.13" tall assembly)
					PN LENGTH
					2A 4.500"
					2B 7.000"
					2C 9.500"
					2D 12.000"
					2Z non-standard length (Note 2)
					ZZ non-standard configuration & length
					BASE EXTRUSION NUMBER
					BE8119 Base profile identifier (SINGLE)
					BE8121 Base profile identifier (DOUBLE)

**Notes:**

1. All non-standard parts must have a modifier.
2. 1Z and 2Z denoting non-standard lengths should only be used for non-standard "A" dimensions. Part # must contain a modifier.
- \*3. When 105 CFM fan (s) used – fan mounting hole pattern for standard axial ("muffin") fan.
- \*\*4. Natural convection based on 50°C heat sink temperature rise above ambient.