

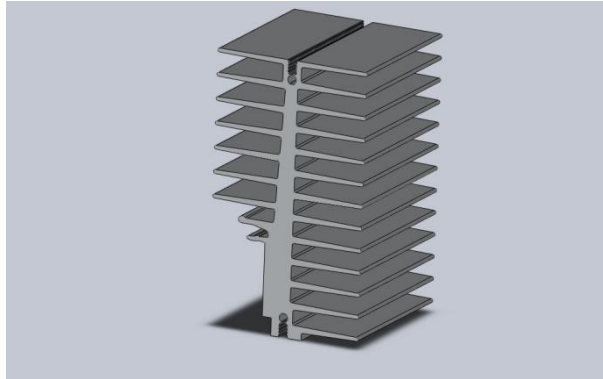

Part Number	Width (mm)	Height (mm)	Linear weight (kg/m)	Rth,n *) (°C/W)	Rth,f **) (°C/W)	Features
RMRES0007	49.5	85	3.47	0.91	0.28	M3 groove

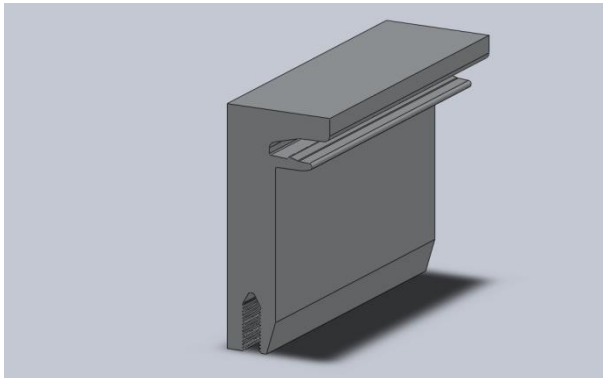

Part Number	Width (mm)	Height (mm)	Linear weight (kg/m)	Rth,n *) (°C/W)	Rth,f **) (°C/W)	Features
RMRES0008	17	37.3	0.85	n.a.	n.a.	M3 groove



Part Number	Width (mm)	Height (mm)	Linear weight (kg/m)	Rth,n *) (°C/W)	Rth,f **) (°C/W)	Features
RMRES0009	38	54	1.69	1.70	0.55	M3 groove

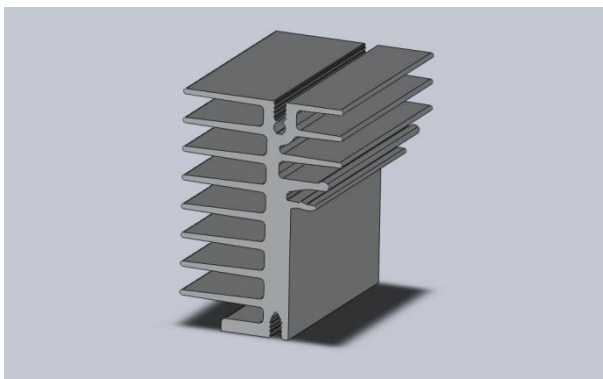



Part Number	Width (mm)	Height (mm)	Linear weight (kg/m)	Rth,n *) (°C/W)	Rth,f **) (°C/W)	Features
RMRES0010	22	28.5	0.49	4.11	1.70	M3 groove

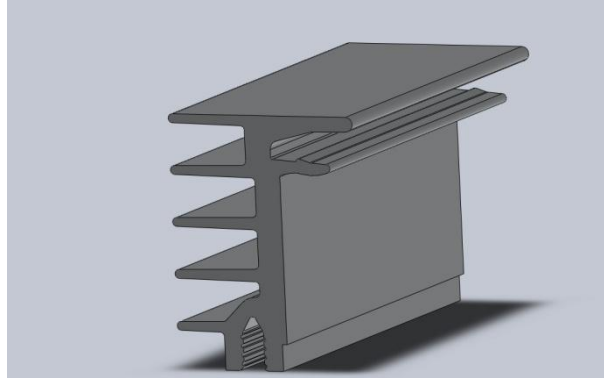

Part Number	Width (mm)	Height (mm)	Linear weight (kg/m)	Rth,n *) (°C/W)	Rth,f **) (°C/W)	Features
RMRES0011	30	57	1.59	2.41	0.76	M4 groove

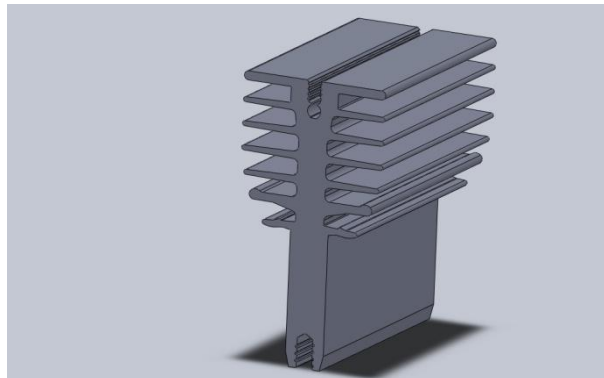

Part Number	Width (mm)	Height (mm)	Linear weight (kg/m)	Rth,n *) (°C/W)	Rth,f **) (°C/W)	Features
RMRES0013	49.5	50	2.16	1.92	0.56	M3 groove

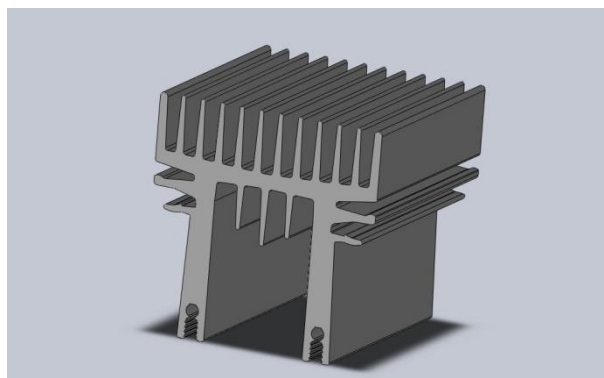



Part Number	Width (mm)	Height (mm)	Linear weight (kg/m)	Rth,n *) (°C/W)	Rth,f **) (°C/W)	Features
RMRES0015	40	40	1.64	2.11	0.64	M3 groove

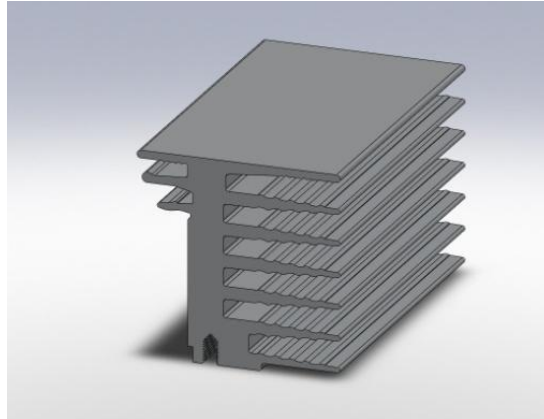

Part Number	Width (mm)	Height (mm)	Linear weight (kg/m)	Rth,n *) (°C/W)	Rth,f **) (°C/W)	Features
RMRES0025	30	47.2	1.31	3.00	0.85	M4 groove

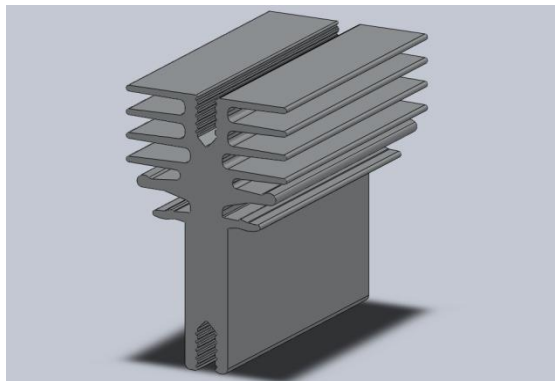

Part Number	Width (mm)	Height (mm)	Linear weight (kg/m)	Rth,n *) (°C/W)	Rth,f **) (°C/W)	Features
RMRES0026	15	54	0.92	3.61	1.55	M3 groove

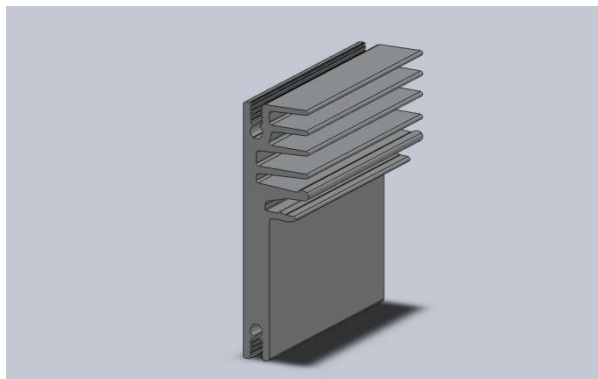



Part Number	Width (mm)	Height (mm)	Linear weight (kg/m)	Rth,n *) (°C/W)	Rth,f **) (°C/W)	Features
RMRES0027	27	60	1.65	2.30	0.53	M4 groove



Part Number	Width (mm)	Height (mm)	Linear weight (kg/m)	Rth,n *) (°C/W)	Rth,f **) (°C/W)	Features
RMRES0028	34	75	2.48	1.44	0.39	M3 & M4 groove

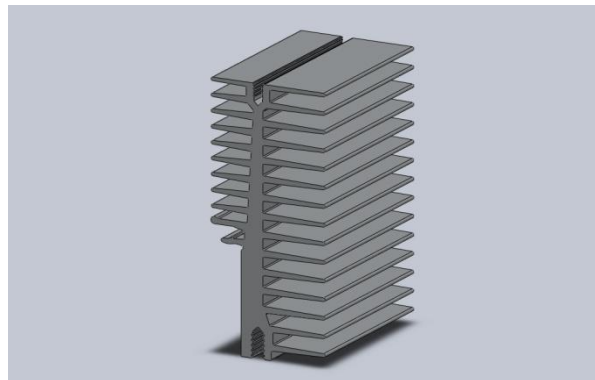

Part Number	Width (mm)	Height (mm)	Linear weight (kg/m)	Rth,n *) (°C/W)	Rth,f **) (°C/W)	Features
RMRES0029	39	32	1.02	3.12	1.03	M3 groove

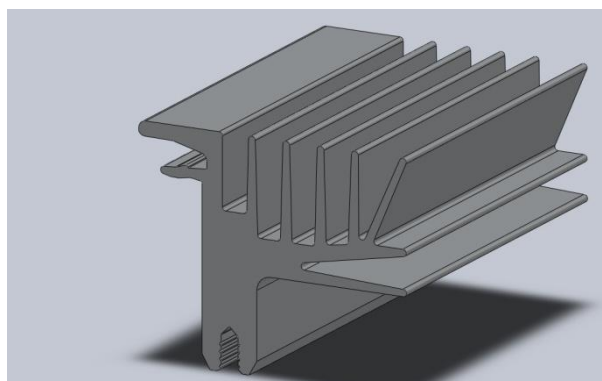



Part Number	Width (mm)	Height (mm)	Linear weight (kg/m)	Rth,n *) (°C/W)	Rth,f **) (°C/W)	Features
RMRES0032	12.6	10.5	0.15	n.a.	n.a.	

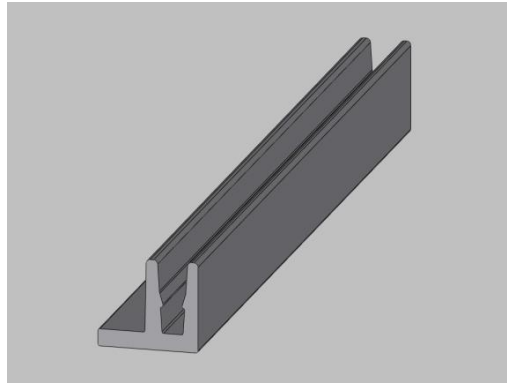

Part Number	Width (mm)	Height (mm)	Linear weight (kg/m)	Rth,n *) (°C/W)	Rth,f **) (°C/W)	Features
RMRES0036	30	45	1.19	2.33	0.75	M3 groove

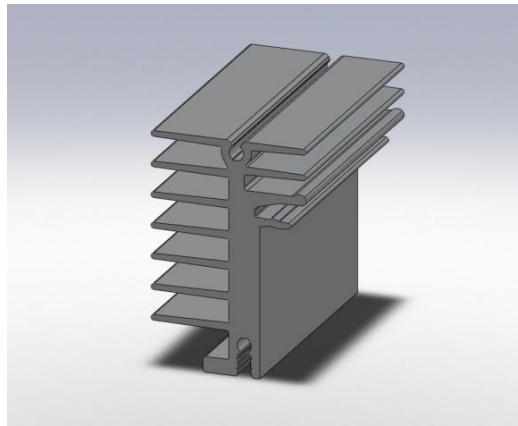

Part Number	Width (mm)	Height (mm)	Linear weight (kg/m)	Rth,n *) (°C/W)	Rth,f **) (°C/W)	Features
RMRES0037	40	75	2.59	1.54	0.39	M3 groove

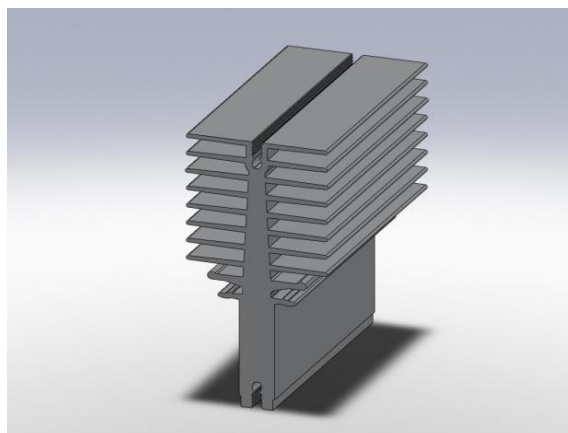



Part Number	Width (mm)	Height (mm)	Linear weight (kg/m)	Rth,n *) (°C/W)	Rth,f **) (°C/W)	Features
RMRES0038	27	29.5	0.96	n.a.	n.a.	M3 groove

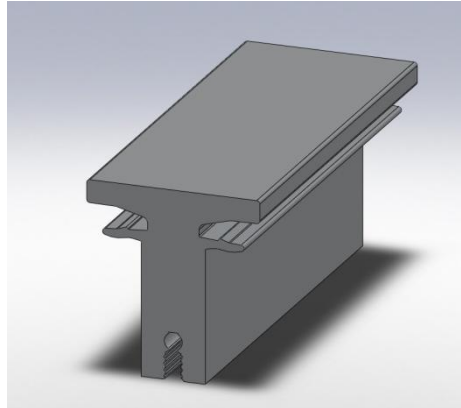

Part Number	Width (mm)	Height (mm)	Linear weight (kg/m)	Rth,n *) (°C/W)	Rth,f **) (°C/W)	Features
RMRES0039	25	36	0.87	n.a.	n.a.	M3 groove

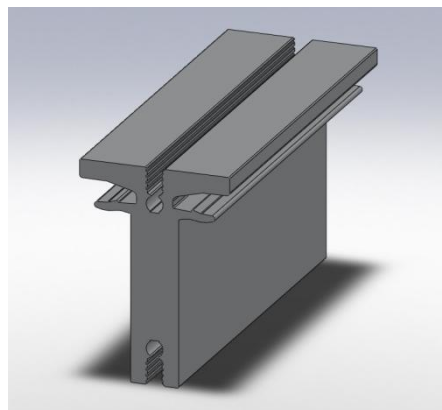

Part Number	Width (mm)	Height (mm)	Linear weight (kg/m)	Rth,n *) (°C/W)	Rth,f **) (°C/W)	Features
RMRES0040	27	50	1.41	2.46	0.66	M3 groove

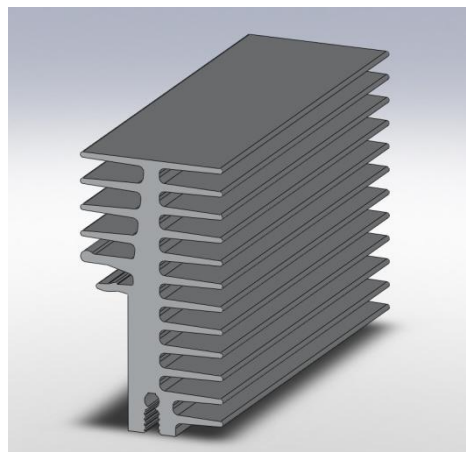



Part Number	Width (mm)	Height (mm)	Linear weight (kg/m)	Rth,n *) (°C/W)	Rth,f **) (°C/W)	Features
RMRES0053	35	90.1	3.08	1.34	0.33	M4 groove

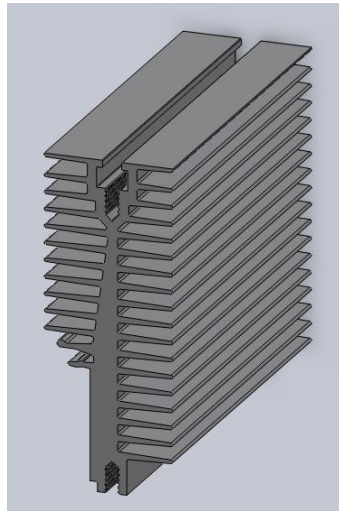

Part Number	Width (mm)	Height (mm)	Linear weight (kg/m)	Rth,n *) (°C/W)	Rth,f **) (°C/W)	Features
RMREC0008	31.8	58.7	1.81	2.32	0.70	M3 groove

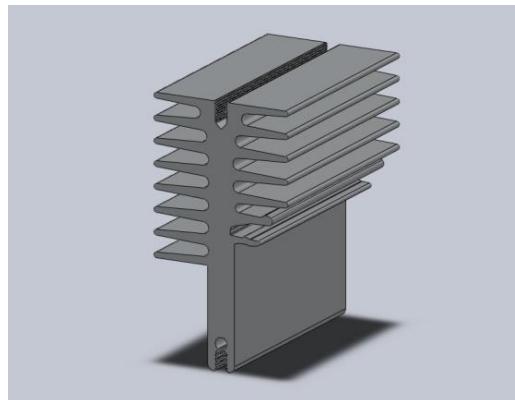

PT clips : steel C67 – Nickel plated

Part Number	Width (mm)	Thickness (mm)	Clamping force by 4,5 mm deformation (N)	Contact Distance (mm)
PT 220 N	10	0.5	22 to 38	14.5

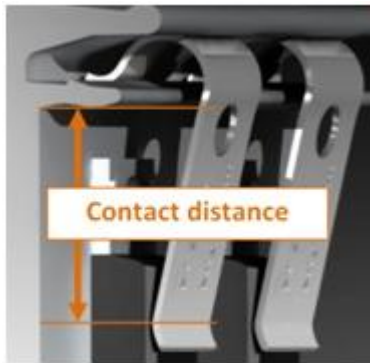

Part Number	Width (mm)	Thickness (mm)	Clamping force by 4,5 mm deformation (N)	Contact Distance (mm)
PT 220 C	10	0.5	45 to 61	10.0

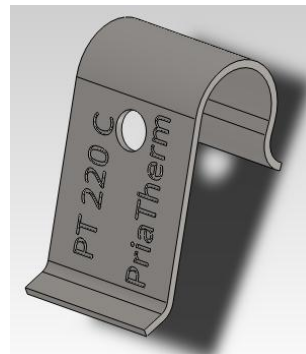

Part Number	Width (mm)	Thickness (mm)	Clamping force by 5 mm deformation (N)	Contact Distance (mm)
PT 247 N	15	0.5	45 to 61	14.5



Part Number	Width (mm)	Thickness (mm)	Clamping force by 5 mm deformation (N)	Contact Distance (mm)
PT 247 S	18	0.6	80 to 108	14.5

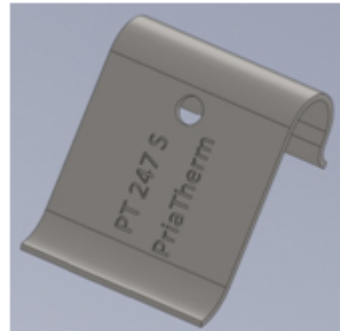

Part Number	Width (mm)	Thickness (mm)	Clamping force by 4,5 mm deformation (N)	Contact Distance (mm)
PT 220 L	12	0.6	40 to 55	19.8

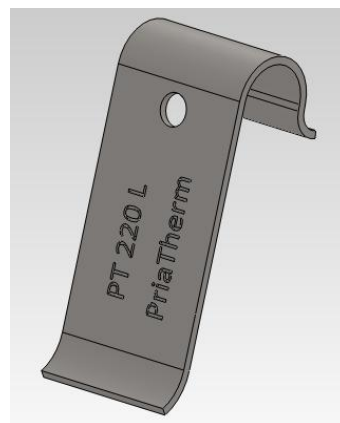

Part Number	Width (mm)	Thickness (mm)	Clamping force by 4,5 mm deformation (N)	Contact Distance (mm)
PT 220 S	13	0.6	60 to 80	14.5





Part Number	Width (mm)	Thickness (mm)	Clamping force by 5 mm deformation (N)	Contact Distance (mm)
PT 247 W	20	0.5	60 to 81	14.5



Part Number	Width (mm)	Thickness (mm)	Clamping force by 4,5 mm deformation (N)	Contact Distance (mm)
PT 220 W	12	0.5	35 to 48	15.5



Part Number	Width (mm)	Thickness (mm)	Clamping force by 3,5 mm deformation (N)	Contact Distance (mm)
PT THIN	6	0.6	20 to 27	19.5



*All PT Clips are available also
Zinc Plated on demand*



Notes about Thermal Resistance values

The R_{th} values in the tables above have been measured by following conditions:

*) $R_{th,n}$ = Thermal resistance by natural convection

- length = 150 mm
- black anodized surface
- vertical oriented
- $T_{ambient} = 25^{\circ}C$
- $T_{heatsink} = 100^{\circ}C$

***) $R_{th,f}$ = Thermal resistance by forced convection

- length=150 mm
- fully ducted air flow
- inlet air speed = 2 m/s
- $T_{ambient} = 25^{\circ}C$
- $T_{heatsink} = 100^{\circ}C$

To calculate thermal resistance, in both natural and forced convection, by lengths other than 150 mm, multiply the given value by a corrective factor as plotted in the graph 1

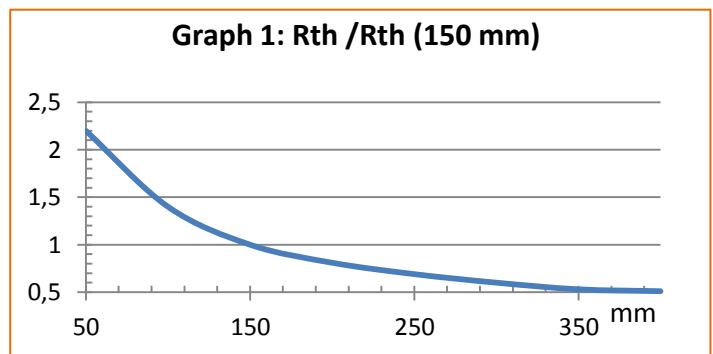

To calculate thermal resistance in natural convection by a temperature rise (heatsink vs. ambient) other than $75^{\circ}C$, use correction factors plotted in graph 2

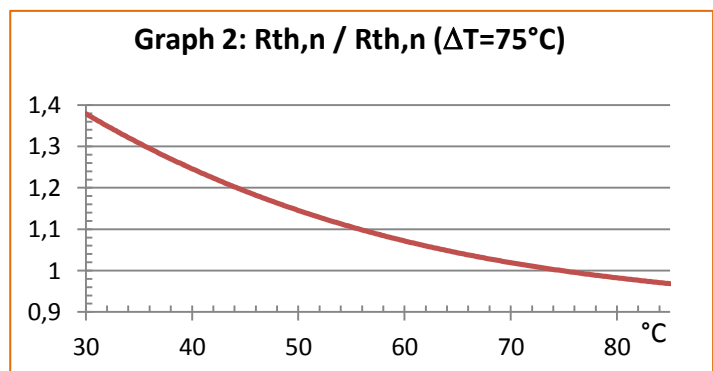

To calculate thermal resistance in forced convection by inlet air speeds other than 2m/s, use correction factors plotted in graph 3

