

4

3

2

1

REVISIONS			
REV	DESCRIPTION	DATE	BY
-	INITIAL RELEASE	06.26.09	HN

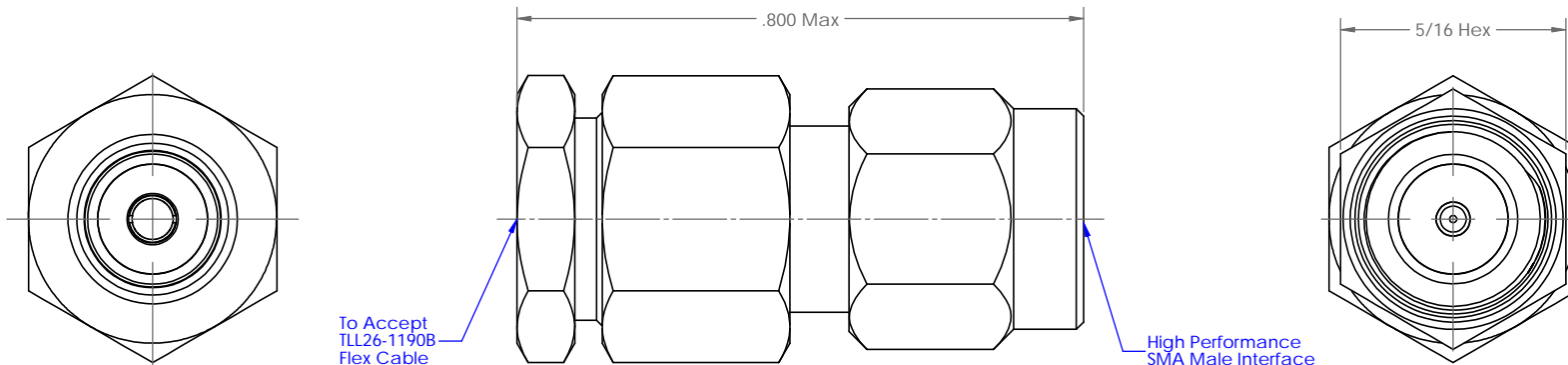
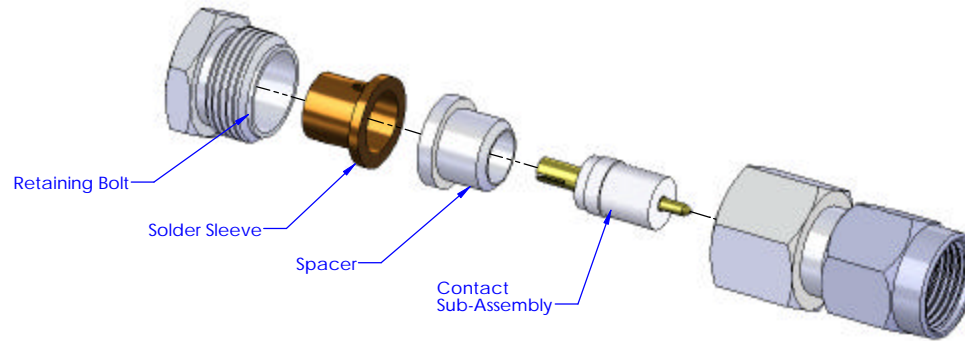

Nothe(s):

1. Retaining Bolt, Solder Sleeve, Spacer and Contact Sub-Assembly to be packaged and shipped unassembled.

MATERIAL:

Body, Coupling Nut, Retaining Bolt, And Spacer:
303 sst per ASTM A 582.

Center Conductor, Solder Sleeve, And Retaining Ring:
BeCu alloy C17300 per ASTM B 196.

Insulator:
Teflon, PTFE, per ASTM D 1710.

Gasket:
Silicone rubber per A- A- 59588.

ELECTRICAL:

Impedance: 50 Ohms Nom.
Freq. Range: DC TO 26 GHz
VSWR: 1.15:1 @ 18GHz
1.20:1 18- 26.5GHz

Insertion Loss: $.019 \sqrt{f(\text{GHz})}$ - .03 dB.
Working Voltage: 190 Vrms @ Sea Level
Dielectric Withstand Voltage: 500 Vrms
RF HiPot Voltage: 250 Vrms Min @ 5MHz
Corona Level: 375 Vrms @ 70,000 ft
Insulation Resistance: 5,000 MegaOhms
Contact Resistance:
Center Conductor: 3.0 Milliohms
RF Leakage: - (90 - fGHz) dB Min.

MECHANICAL:

Mating Characteristics:
High performance SMA male Interface
Force To Engage & Disengage:
Torque: 2 inch- pounds max
Longitudinal Force: NA
Connector Durability:
500 cycles min @ 12 cycles/minute max
Coupling Proof Torque: 15 inch- pounds min.
Coupling Mech. Retention: 60 pounds min.
Permeability: Less than 2.0 mu.

ENVIRONMENTAL:

Temp. Range: - 65°C to +165°C
Thermal Shock:
MIL- STD- 202, Method 107, Test Cond. B
Moisture Resistance:
MIL- STD- 202, Method 106. Insulation resistance at least 200 MegaOhms within 5 minutes after removal from humidity
Corrosion:
MIL- STD- 202, Method 101, Test Cond. B
Vibration:
MIL- STD- 202, Method 204, Test Cond. D
Shock:
MIL- STD- 202, Method 213, Test Cond. I

FINISH(ES):

Center Conductor:
Gold plate per ASTM B 488, Type II, Code C or D, Class 1.25, over nickel under plate per SAE- AMS- QQ- N- 290, Class 1.

Solder Sleeve:
Gold plate per ASTM B 488, Type II, Code C, Class 0.25, over nickel under plate per SAE- AMS- QQ- N- 290, Class 1.

Body, Coupling Nut And Retaining Bolt:
Passivate per ASTM A 967 or AMS- QQ- P- 35.

APPLICABLE CARLISLE IT DOCUMENTS

WORK STANDARD	PROD INSTRUC	ASSY INSTRUC
NA	NA	AI-686

NOTICE
THIS DRAWING EMBODIES A CONFIDENTIAL PROPRIETARY DESIGN ORIGINATED BY CARLISLE INTERCONNECT TECHNOLOGIES & ALL DESIGN, MANUFACTURING, REPRODUCTION, USE & SALE RIGHTS REGARDING THE SAME ARE EXPRESSLY RESERVED. IT IS SUBMITTED UNDER A CONFIDENTIAL RELATIONSHIP FOR A SPECIFIC PURPOSE & THE RECIPIENT AGREES BY ACCEPTING THIS DRAWING NOT SUPPLY OR DISCLOSE ANY INFORMATION REGARDING IT TO ANY UNAUTHORIZED PERSON TO INCORPORATE IN OTHER PROJECTS ANY SPECIAL FEATURES PECULIAR TO THIS DESIGN. ALL PATENT RIGHTS HERE-TO ARE EXPRESSLY RESERVED BY CARLISLE INTERCONNECT TECHNOLOGIES, LONG BEACH, CALIFORNIA 90815.

TOLERANCES AND NOTES

- EXCEPT AS NOTED
DIMENSIONS ARE IN INCHES.
LINEAR $\pm .005$ ANGULAR $\pm 1/2^\circ$
FRACTION $\pm 1/32$
1. MACHINE FINISH: $\frac{16}{32}$ RMS
 2. BREAK ALL SHARP EDGES .003 MAX.
 3. MACHINED FILLETS .005 MAX.
 4. MACHINED SURFACES SQUARE TO RESPECTIVE AXES WITHIN .002 INCHES PER INCH.
 5. MACHINED DIAMETERS CONCENTRIC WITHIN .002 TLR.
 6. DIMENSIONS TO BE MET BEFORE PLATING.
 7. CHAMFER ALL THREADS 45°.
 8. THREADS PER H 28
 9. REMOVE FRAYED EDGES ON TEFLON.
 10. REMOVE ALL BURRS.

APPROVAL		MATERIAL		SIZE		SPECIFICATION		PROCUREMENT	
INITIALS	DATE								
YPHAN	03.19.08								
DNg	06.26.09								
TEST ENGR									
DESIGN ENGR	HN								
MFG. ENGR									
TITLE		SCALE		SUB-DIRECTORY FILE NAME		SHEET 1 OF 1		REV.	
HIGH PERFORMANCE, SMA MALE STRAIGHT FOR TLL26-1190B FLEX CABLE		1:1		OL/		5755-7CCSF		-	
C 30990		CAGE CODE DRAWING NO.		5755-7CCSF					

ENG- DWG REV. C

4

3

2

1