



## 0.47- 0.96 GHz UHF 10 W LOW NOISE POWER AMPLIFIER WPA0510A<sup>1</sup>

WPA0510A is a low noise figure, wideband, and high linearity class A operation power amplifier. The amplifier offers typical 40.0 dBm output P<sub>1dB</sub>, 0.90 dB noise figure, 50 dB gain, and 52.0 dBm output IP<sub>3</sub> at the frequency range from 0.47 GHz to 0.96 GHz of UHF and Cellular bands. WPA0510A can withstand output open or short load mismatch.

WPA0510A is most suitable for UHF digital broadcast, cellular base stations, wireless data communications, tower top receiver amplifiers, last-mile wireless communication systems, and wireless measurement applications.

WPA0510A is designed to meet the rugged standard of MIL-STD-202.



### Key Features:

Impedance:	50 Ohm	<b>Preliminary</b>
MTBF <sup>2</sup> :	>100,000 hrs	
Unconditional Stable:	k>1	
Maximum Output Load Mismatch:	∞:1	
Low Noise:	0.90 dB	
Output IP <sub>3</sub> :	52.0 dBm	
Gain:	50.0 dB	
P <sub>1dB</sub> :	40.0 dBm	
Single Power Supply:	1.60A @ +28V	
Wide Bandwidth:	0.47 ~ 0.96 GHz	
Operating Temperature:	-10 ~ +85 °C	

**!! Additional heat sink required for normal operation.**

Input & Output Return Losses:	20.0 dB
Small size:	Pallet format, 3.5" x 1.8" x 0.7" (87.5 mm x 45.7 mm x 17.8 mm)

### Absolute Maximum Ratings<sup>3</sup>:

Symbol	Parameters	Units	Absolute Maximum
V <sub>dd</sub>	DC Power Supply Voltage	V	30
I <sub>dd</sub>	Drain Current	A	2.0
P <sub>diss</sub>	Total Power Dissipation	W	50
P <sub>In,Max</sub>	RF Input Power	dBm	0
T <sub>ch</sub>	Channel Temperature	°C	170
T <sub>STG</sub>	Storage Temperature	°C	-55 ~ 125
T <sub>O,MAX</sub>	Maximum Operating Temperature	°C	-40 ~ 85
R <sub>th,c</sub>	Thermal Resistance	°C/W	3.5 <sup>4</sup>

<sup>1</sup> Specifications are subject to change without notice.

<sup>2</sup> MTBF: Mean Time Between Failure, Per TR-NWT-000332, ISSUE 3, SEPTEMBER, 1990, T=40°C

<sup>3</sup> Operation of this device above any one of these parameters may cause permanent damage.

<sup>4</sup> Case to the junction of last stage single power transistor.



**Specifications:**

**Table 1** Summary of the electrical specifications WPA0510A at room temperature

Index	Testing Item	Symbol	Test Constraints	Nom (RT)	Min	Max	Unit
1	Gain	$S_{21}$	0.47 – 0.96 GHz	50			dB
2	Gain Variation	$\Delta G$	0.47 – 0.96 GHz	+/- 0.75		+/-1.25	dB
3	Input Return Loss	$S_{11}$	0.47 – 0.96 GHz	20	16		dB
4	Output Return Loss	$S_{22}$	0.47 – 0.96 GHz	20	14		dB
5	Reverse Isolation	$S_{12}$	0.47 – 0.96 GHz	50			dB
6	Noise figure	NF	0.47 – 0.96 GHz	0.90		1.1	dB
7	Output Power 1dB compression Point	$P_{1dB}$	0.47 – 0.96 GHz	41	39		dBm
8	Output-Third-Order Interception point	$IP_3$	Two-Tone, $P_{out}$ = 33.0 dBm each, 1 MHz separation	52	50		dBm
9	Current Consumption	$I_{dd}$	$V_{dd}$ = +28 V	1.60			A
10	Power Supply Voltage	$V_{dd}$		+28	+24	+30	V
11	Power Added Efficiency	$\eta$	$V_{dd}$ = +28 V, $P_o$ = $P_{1dB}$	30			%
12	Thermal Resistance	$R_{th,c}$	Junction to case			3.5	°C/W
13	Operating Temperature	$T_o$			-10	+85	°C
14	Maximum Average RF Input Power	$P_{IN,MAX}$	0.47 – 0.96 GHz			0	dBm

As shown in **Figure 1**, the typical small signal gain of the WPA0510A is 50.0 dB across 0.47 GHz to 0.96 GHz. The amplifier provides excellent gain flatness across the passband. The typical input and output return losses are 20 dB in the passband.

**Figure 2** shows  $P_{1dB}$  of WPA0510A. The typical  $P_{1dB}$  is greater than 40 dBm in the frequency range of 0.47 GHz to 0.96 GHz.

**Figure 3** illustrates the  $IP_3$  performance at different frequency at different output power level. The output  $IP_3$  reaches 51.0 dBm even at the total output power level of 38 dBm. **Figure 4** is the  $IP_3$  performance varies with the output power level. The amplifier maintains excellent linearity at the total output power of 36 dBm.

**Figure 5** illustrates the noise figure performance of WPA0510A. The noise figure is 0.90 dB across the frequency range of 0.47 GHz to 0.96 GHz at room temperature.

**Figure 6** is the plot of the stability factor  $k$  of WPA0510A. The amplifier is unconditional stable since the stability factor  $k$  is greater than 1 at all frequency ranges.

**Figure 7** demonstrates the small signal performance of WPA0510A at the extended frequency range at room temperature. The amplifier works well from 0.40 GHz to 1.1 GHz frequency range.

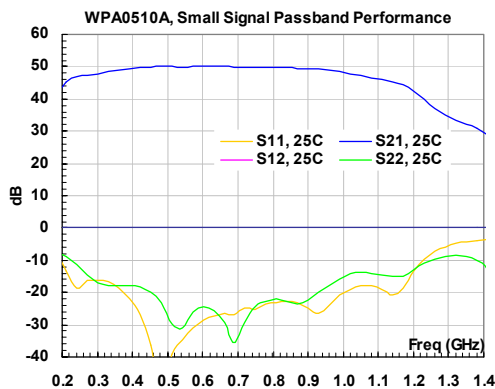

**FIG. 1** Typical small signal performance.

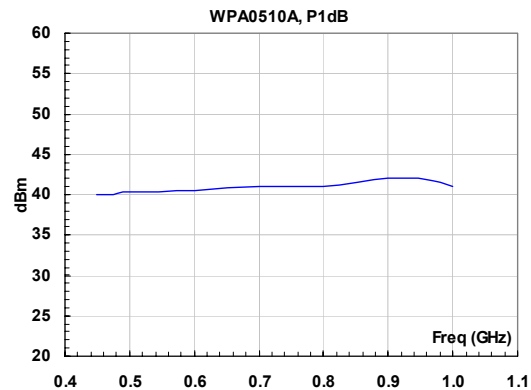

**FIG. 2** Typical  $P_{1dB}$  performance.

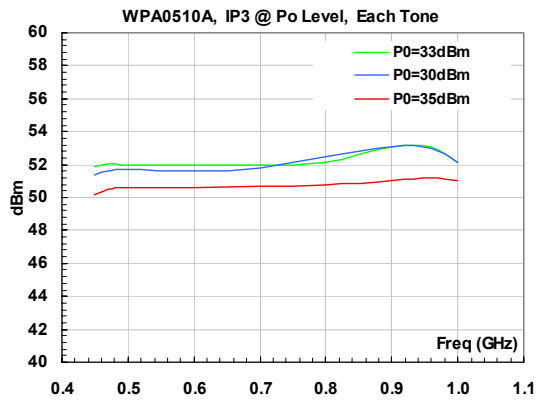

FIG. 3 IP<sub>3</sub> Performance vs. frequency

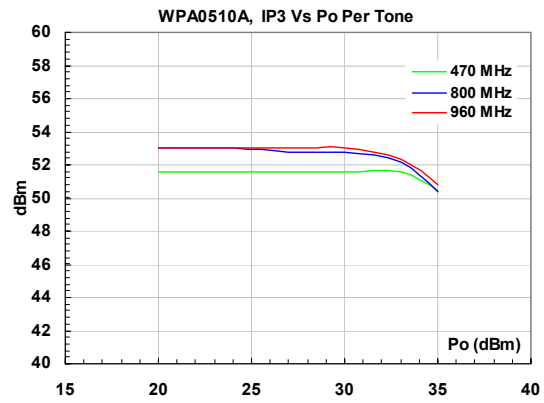

FIG. 4 IP<sub>3</sub> Performance vs. output power

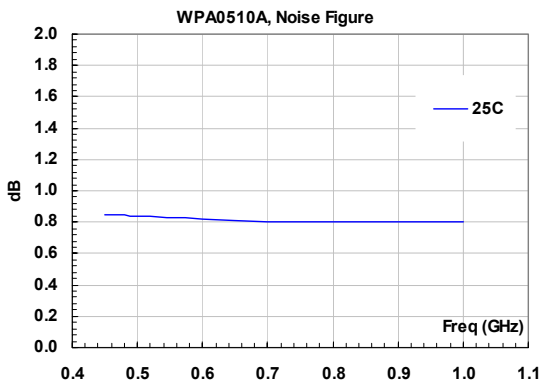

FIG. 5 Noise figure performance

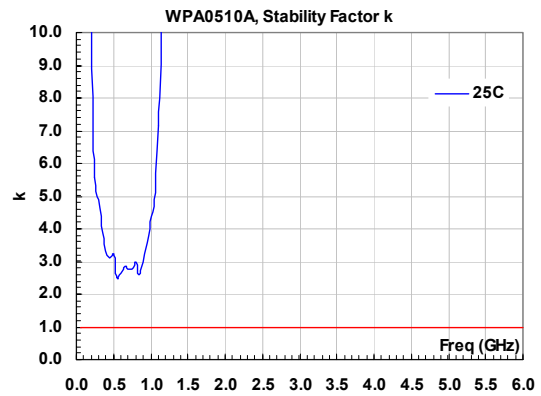

FIG. 6 Stability factor  $k$  of WPA0510A

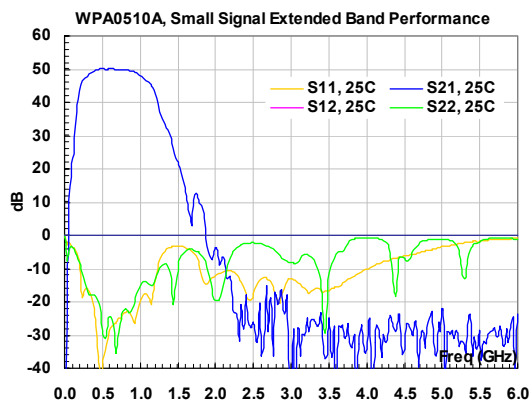

FIG. 7 Performance at the extended frequency band

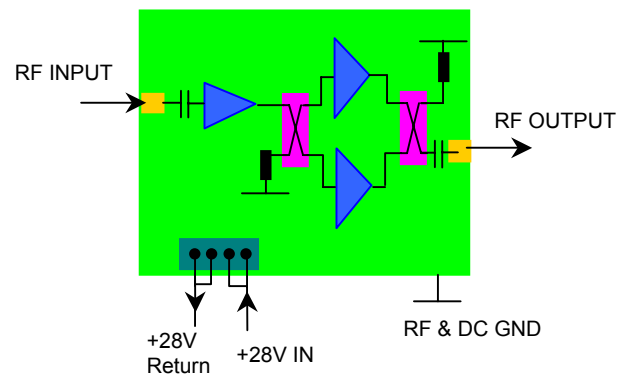
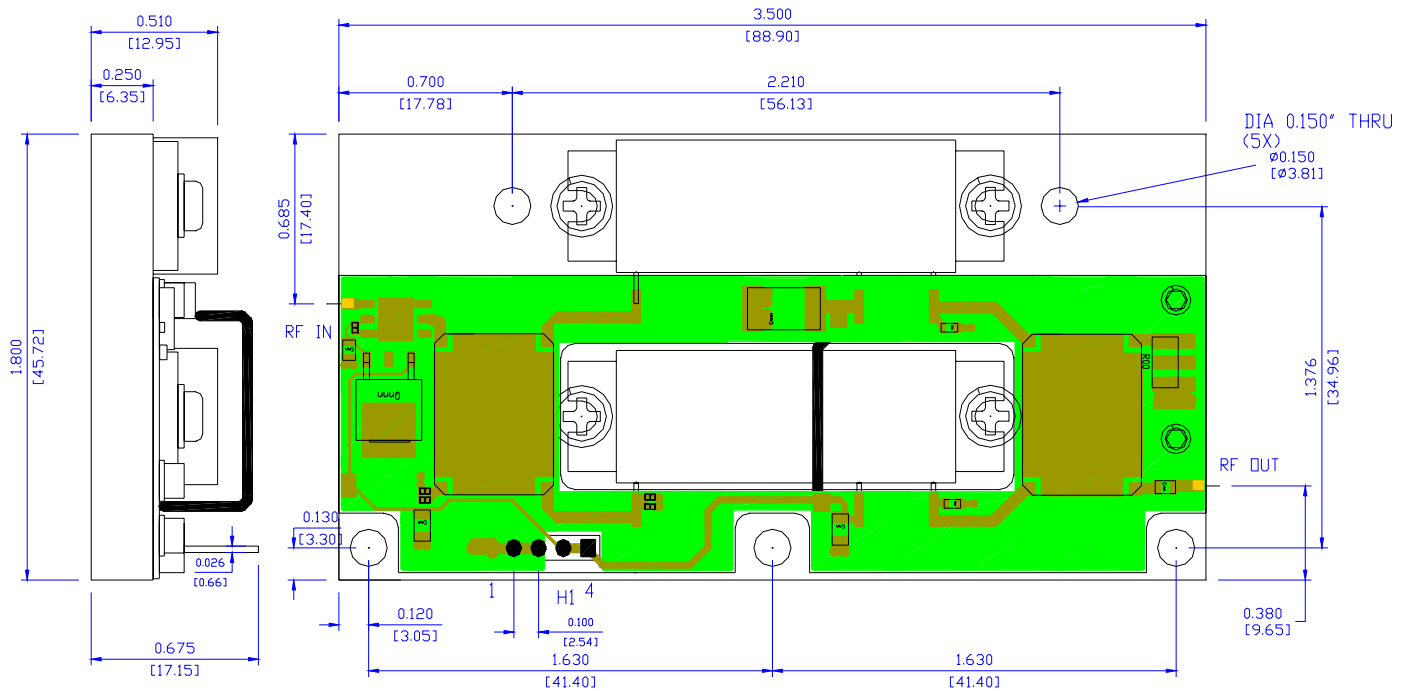

FIG. 8 Block diagram of WPA0510A



**NOTES**

- 1. BASE MATERIAL: ALUMINUM ALLOY 6061
- 2. TOLERANCE IS NON-ACCUMULATIVE.

PIN	1, 2	3, 4
FUNCTION	+28V Return	+28V IN

**FIG. 9** WPA0510A outline

Figure 8 demonstrates the internal block diagram of the amplifier. The amplifier has balanced design at the output stage for output load high mismatch protection and excellent VSWR performance.

**WPA0510A Mechanical Outline:**

Figure 9 shows the mechanical outline of WPA0510A. The amplifier module is mounted on a 3.5" x 1.8" x 0.25" aluminum alloy base plate. The plate has five (5) mounting thru holes for securing the amplifier to a larger heat sink. RF I/O ports are microstrip launch, which can be easily soldered to a connector such as SMA type. +28V DC power supply is fed into pin 3 and 4 of the header H<sub>1</sub> that has 0.10" pitch.

**Ordering Information**

<b>Model Number:</b>	WPA0510A
----------------------	----------

\*\*\*\*\*