

FEATURES

- Low Cost Integrated Monolithic GaAs Amplifier With Step Attenuator
- Attenuation Range: 0-30 dB, Adjustable In 2dB Increments Via a 4 Wire Parallel Control
- Meets DOCSIS Distortion Requirements at +58dBmV Output Signal Level
- Low Distortion and Low Noise
- Low Signal toNoise Ratio at All Gain Levels
- Frequency Range: 5-100 MHz
- 5 Volt Operation
- RoHS-Compliant Package Option

APPLICATIONS

- MCNS/DOCSIS Compliant Cable Modems
- CATV Interactive Set-Top Box
- OpenCable Set-Top Box
- Fiber Nodes
- Cable Modem Termination Systems (CMTS)



PRODUCT DESCRIPTION

The ARA05050 is a GaAs IC designed to provide the reverse path amplification and output level control functions in a CATV Set-Top Box or Cable Modem. It incorporates a digitally controlled precision step attenuator that is preceded by an ultra low noise amplifier stage, and followed by an ultra-linear output driver amplifier. This device is capable of meeting the MCNS/DOCSIS requirements for harmonic

performance at a +58dBmV output level while requiring only a single polarity +5V supply. Both the input and the output are single-ended and matched to 75 Ohms. The precision attenuator provides up to 30 dB of attenuation in 2 dB increments. The ARA05050 is offered in a 28-pin SSOP package that features a heat slug on the bottom of the package, and is available in a RoHS-compliant option.

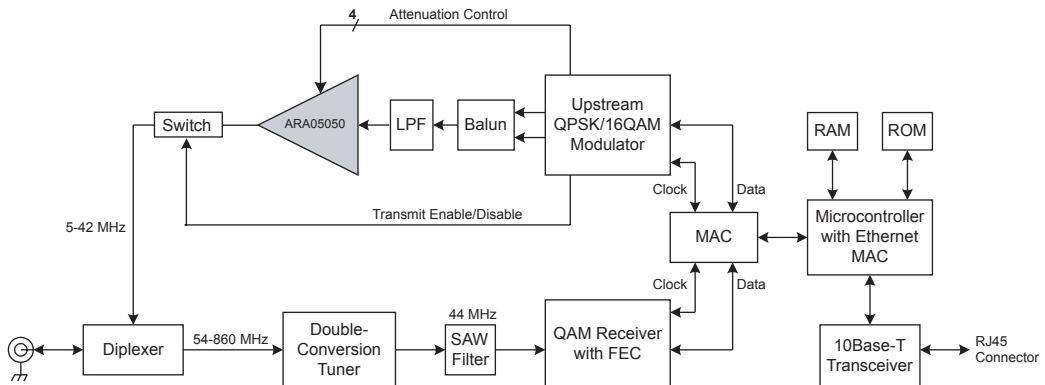

Figure 1. Cable Modem or Set Top Box Application Diagram

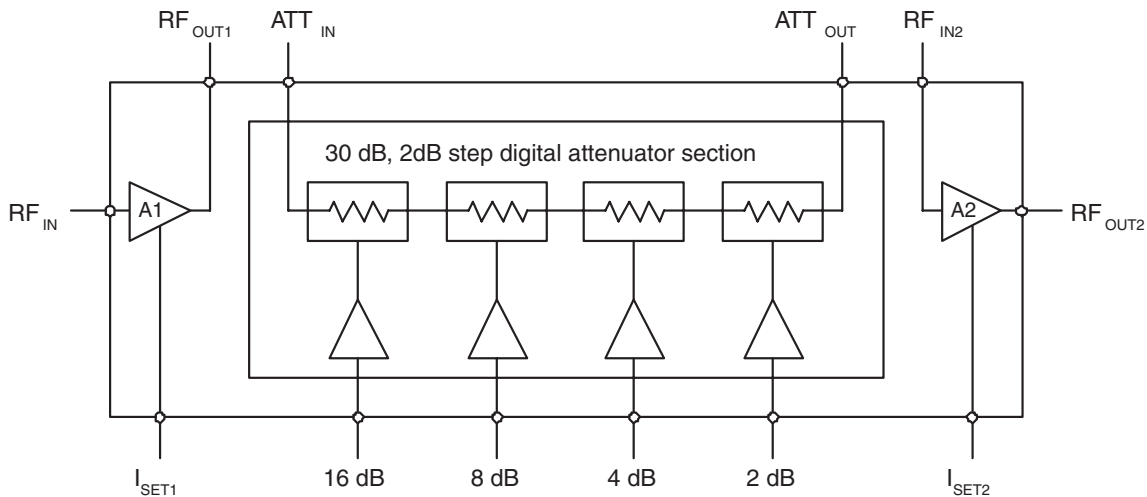

Figure 2: Functional Block Diagram

1	N/C	N/C	28
2	Bypass	N/C	27
3	ATT _{IN}	ATT _{OUT}	26
4	RF _{OUT1}	I _{SET2}	25
5	V _{REF1}	RF _{IN2}	24
6	ATT _{ACG1}	ATT _{ACG2}	23
7	ATT _{ACG1}	ATT _{ACG2}	22
8	ATT _{ACG1}	ATT _{ACG2}	21
9	ATT _{ACG1}	ATT _{ACG2}	20
10	RF _{IN}	V _{REF2}	19
11	I _{SET1}	RF _{OUT2}	18
12	V _{ATT}	GND	17
13	16 dB	2 dB	16
14	8 dB	4 dB	15

Figure 3: Pinout

Table 1: Pin Description

PIN	NAME	DESCRIPTION	PIN	NAME	DESCRIPTION
1	N/C	No Connection ⁽¹⁾	28	N/C	No Connection ⁽¹⁾
2	Bypass	Internal Bypass	27	N/C	No Connection ⁽¹⁾
3	ATT _{IN}	Attenuator Input ⁽²⁾	26	ATT _{OUT}	Attenuator Output ⁽²⁾
4	RF _{OUT1}	Amplifier A1 Output and Supply	25	I _{SET2}	Amplifier A2 Current Adjust ⁽⁴⁾
5	V _{REF1}	Reference Voltage for Amplifier A1	24	RF _{IN2}	Amplifier A2 Input ⁽⁴⁾
6	ATT _{ACG1}	Attenuator AC Ground 1 ⁽³⁾	23	ATT _{ACG2}	Attenuator AC Ground 2 ⁽³⁾
7	ATT _{ACG1}	Attenuator AC Ground 1 ⁽³⁾	22	ATT _{ACG2}	Attenuator AC Ground 2 ⁽³⁾
8	ATT _{ACG1}	Attenuator AC Ground 1 ⁽³⁾	21	ATT _{ACG2}	Attenuator AC Ground 2 ⁽³⁾
9	ATT _{ACG1}	Attenuator AC Ground 1 ⁽³⁾	20	ATT _{ACG2}	Attenuator AC Ground 2 ⁽³⁾
10	RF _{IN}	Amplifier A1 Input ⁽⁴⁾	19	V _{REF2}	Reference Voltage for Amplifier A2
11	I _{SET1}	Amplifier A1 Current Adjust ⁽⁴⁾	18	RF _{OUT2}	Amplifier A2 Output and Supply
12	V _{ATT}	Attenuator Supply	17	GND	Ground
13	16 dB	16 dB Attenuation Control Bit	16	2 dB	2 dB Attenuation Control Bit
14	8 dB	8 dB Attenuation Control Bit	15	4 dB	4 dB Attenuation Control Bit

Notes:

(1) All N/C pins should be grounded.

(2) Pins should be AC-coupled. No external DC bias should be applied.

(3) Pins should be AC-grounded. No external DC bias should be applied.

(4) Pins should be grounded or pulled to ground through a resistor. No external DC bias should be applied.

ELECTRICAL CHARACTERISTICS

Table 2: Absolute Minimum and Maximum Ratings

PARAMETER	MIN	MAX	UNIT
Analog Supply: V_{SUP} (pins 4, 12, 18)	0	9	VDC
Amplifier Reference Voltages (pins 5, 19)	-2.5	$\frac{V_{SUP}}{2}$	VDC
RF Power at Amplifier Inputs (pins 10, 24)	-	+60	dBmV
Attenuator Controls (pins 13, 14, 15, 16)	0	6	V
Storage Temperature	-55	+200	°C
Soldering Temperature	-	260	°C
Soldering Time	-	5	Sec

Stresses in excess of the absolute ratings may cause permanent damage. Functional operation is not implied under these conditions. Exposure to absolute ratings for extended periods of time may adversely affect reliability.

Notes:

1. Pins 3 and 26 should be AC-coupled. No external DC bias should be applied.
2. Pins 10, 11, 24 and 25 should be grounded or pulled to ground through a resistor. No external DC bias should be applied.
3. Pins 6, 7, 8, 9, 20, 21, 22 and 23 should be AC-grounded. No external DC bias should be applied.

Table 3: Operating Ranges

PARAMETER	MIN	TYP	MAX	UNIT
Amplifier Supply: V_{DD} (pins 4, 18)	4.5	5	7	VDC
Attenuator Supply: V_{ATTN} (pin 12)	-	5	7	VDC
Attenuator Controls (pins 13, 14, 15, 16)	0	-	5.5	V
Amplifier Reference Voltages (pins 5, 19)	-	1.75	-	VDC
Output Switch Control (pin 25)	0	-	5.5	V
Case Temperature	-40	25	85	°C

The device may be operated safely over these conditions; however, parametric performance is guaranteed only over the conditions defined in the electrical specifications.

Table 4: DC Electrical Specifications

T_A=25°C; V_{DD}, V_{ATTN} = +5.0 VDC

PARAMETER	MIN	TYP	MAX	UNIT	COMMENTS
Amplifier A1 Current (pin 4)	-	75	95	mA	
Amplifier A2 Current (pin 18)	-	100	130	mA	
Attenuator Current (pin 12)	-	8	-	mA	
Total Power Consumption	-	0.92	1.2	W	

Table 5: AC Electrical Specifications

T_A=25°C; V_{DD}, V_{ATTN} = +5.0 VDC

PARAMETER	MIN	TYP	MAX	UNIT	COMMENTS
Gain (10 MHz) ARA05050 ARA05050R	30 31	32 32	33 33	dB	0 dB attenuation setting
Gain Flatness	-	0.75	1.5	dB	5 to 100 MHz
Gain Variation over Temperature	-	-0.006	-	dB/°C	
Attenuation Steps 2 dB 4 dB 8 dB 16 dB	1.6 3.8 8.0 16.0	1.85 4.0 8.3 16.6	2.2 4.2 8.5 17.0	dB	5 to 42 MHz ⁽¹⁾ , Monotonic
2 nd Harmonic Distortion Level 5 MHz 25 MHz	- -	-60 -63	-55 -55	dBc	+58 dBmV into 75 Ohms
3 rd Harmonic Distortion Level 5 MHz 25 MHz	- -	-63 -63	-60 -60	dBc	+58 dBmV into 75 Ohms
3 rd Order Output Intercept	78	-	-	dBmV	
1 dB Gain Compression Point	-	70	-	dBmV	
Noise Figure	-	1.7	2.5	dB	

Notes:

(1) See Figures 5 and 6 for performance at higher frequencies.
All specifications as measured in ANADIGICS test fixture.

continued: AC Electrical Specifications

T_A=25°C; V_{DD}, V_{ATTN} = +5.0 VDC

PARAMETER	MIN	TYP	MAX	UNIT	COMMENTS
Output Noise Power Active/No Signal/Min. Atten. Set. Active/No Signal/Max. Atten. Set.	- -	- -	- -	dBmV	Any 160 kHz bandwidth from 5 to 42 MHz
Input Impedance	-	-75	-	Ohms	
Input Return Loss	-	-20	-15	dB	75 Ω system
Output Impedance	-	75	-	Ohms	
Output Return Loss	-	-20	-15	dB	75 Ω system

Note: As measured in ANADIGICS test fixture

Table 6: Logic Interface Specifications

T_A=25°C; V_{DD}, V_{ATTN} = +5.0 VDC

PARAMETER	MIN	TYP	MAX	UNIT	COMMENTS
Attenuator Control Logic V _{IN,LOW} V _{IN,HIGH}	0 2.8	- -	0.5 5.5	V	Bypasses atten. stage Enables atten. stage
Attenuator Control Impedance	-	5 K	-	Ohms	

Note:

(1) Specification applies when 470 Ohm resistor is connected from pin 2 to ground (see test circuit in Figure 4).

Table 7: Attenuator Logic

ATTENUATION (dB)	0	2	4	6	8	10	12	14	16	18	20	22	24	26	28	30
2 dB Logic Input (pin 16)	L	H	L	H	L	H	L	H	L	H	L	H	L	H	L	H
4 dB Logic Input (pin 15)	L	L	H	H	L	L	H	H	L	L	H	H	L	L	H	H
8 dB Logic Input (pin 14)	L	L	L	L	H	H	H	H	L	L	L	L	H	H	H	H
16 dB Logic Input (pin 13)	L	L	L	L	L	L	L	L	H	H	H	H	H	H	H	H

Note: "L" = logic low, "H" = logic high

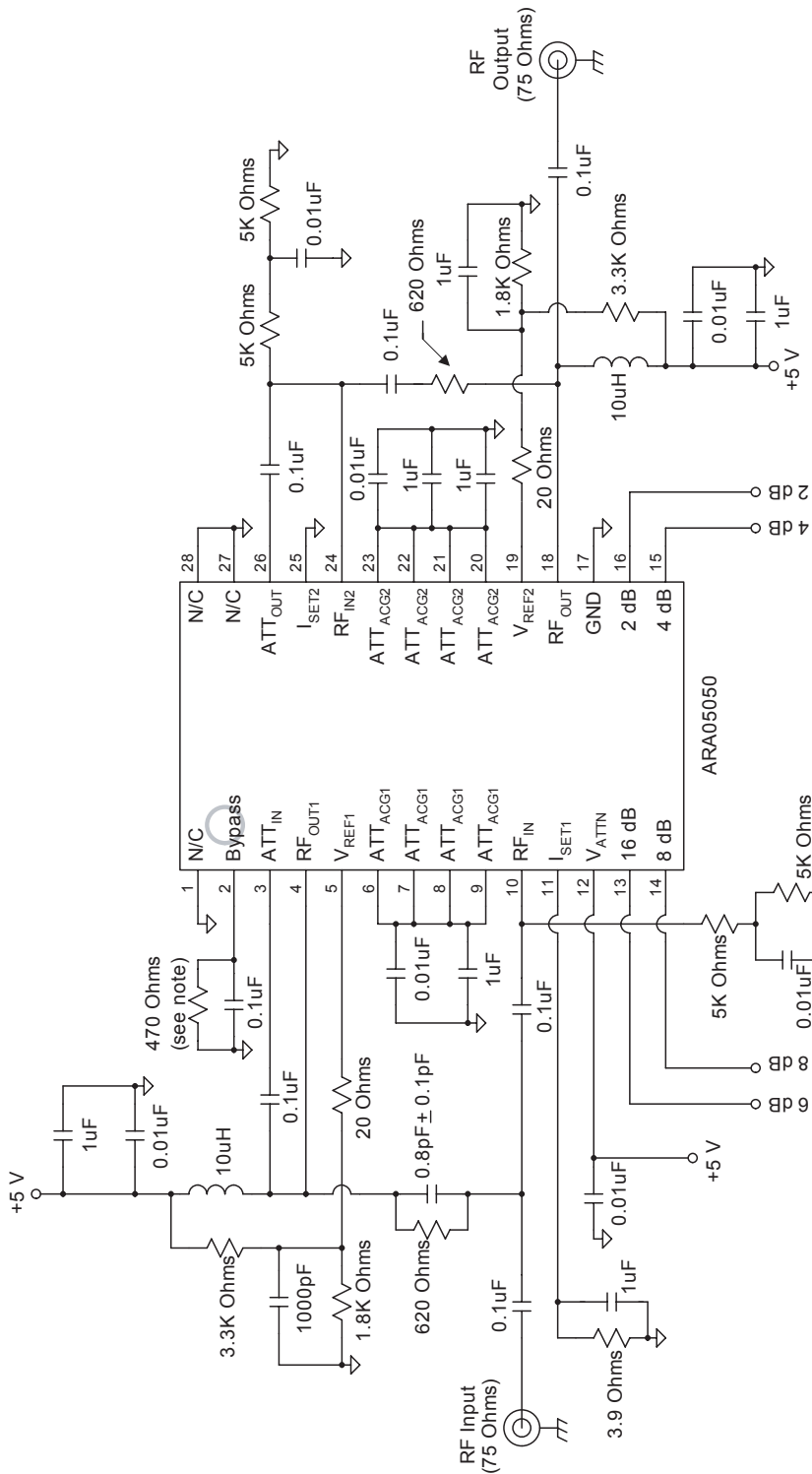

Note:
 The 470 Ohm resistor from pin 2 to ground is installed for 3V attenuator control logic levels. For 5V logic, the 470 Ohm resistor is removed.

Figure 4: Test Circuit

PERFORMANCE DATA

Figure 5: S21 (0 - 16 dB Attenuation)

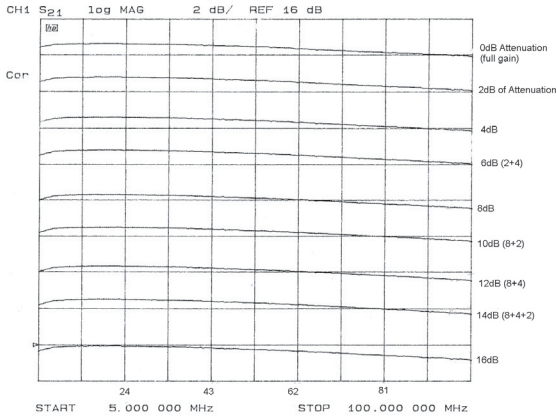

Figure 6: S21 (16 - 30 dB Attenuation)

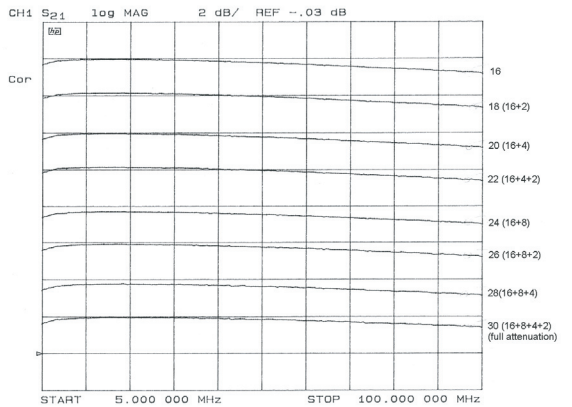

Figure 7: S11 - Log Scale

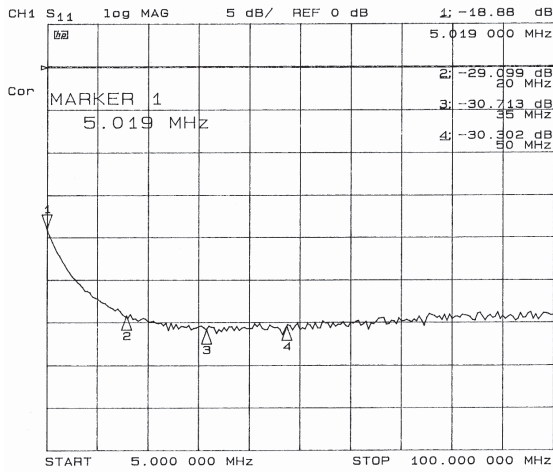

Figure 8: S22 - Log Scale

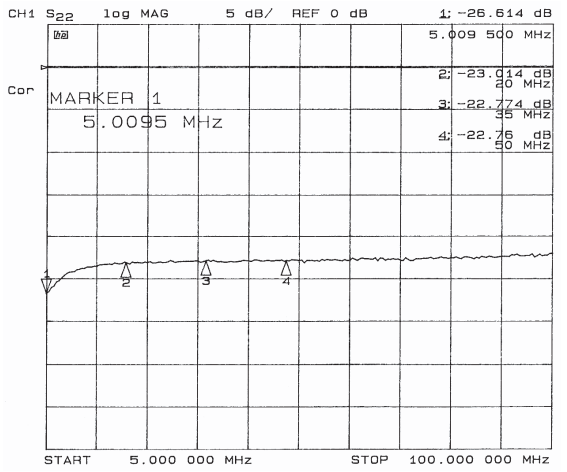

Figure 9: S11 - Smith Chart

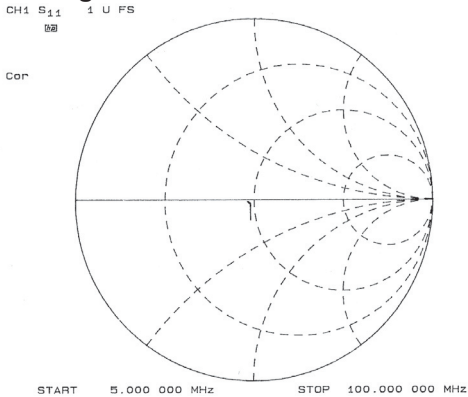

Figure 10: S22 - Smith Chart

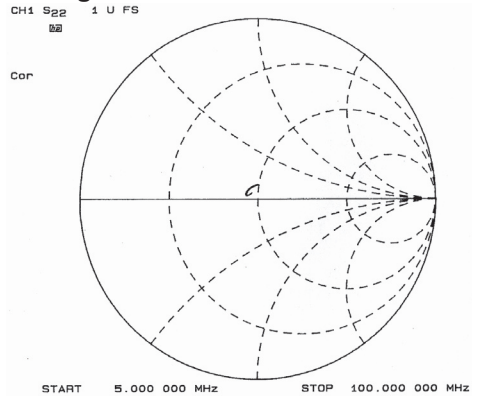

Figure 11: Attenuator Switching Speed - 16 dB Step

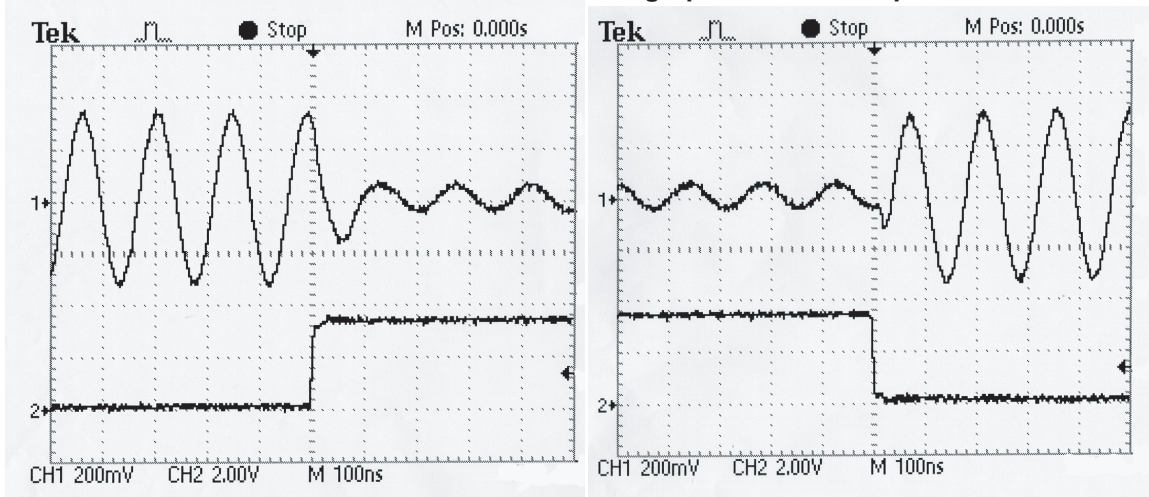
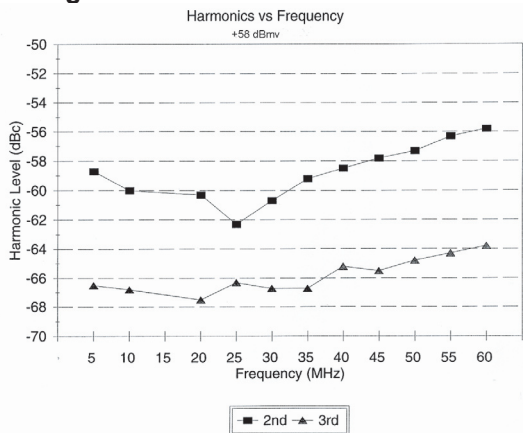

Figure 12: Harmonic Performance



APPLICATION INFORMATION

Printed Circuit Board Layout Considerations

The ARA05050 is a high-performance RF device. Special consideration must be given to certain features of the the printed circuit board layout, as they can affect the RF performance of the IC. Refer to the ANADIGICS application note “CATV Reverse Amp w/ Step Attenuator” for more details.

Amplifier Enable / Disable

The ARA05050 includes two amplification stages that each can be shut down through external control pins V_{REF1} and V_{REF2} (pins 5 and 19, respectively.) By applying a typical bias of 1.75 Volts to these pins, the amplifiers are enabled. In order to fully disable an amplifier, its control pin requires a negative bias of -1.5 to -2.0 Volts.

Amplifier Bias Current

The I_{SET} pins (11 and 25) set the bias current for the amplification stages. Grounding these pins results in the maximum possible current. By placing a resistor from the pin to ground, the current can be reduced. The recommended bias conditions use the configuration shown in the test circuit schematic in **Figure 4**.

Thermal Layout Considerations

The device package for the ARA05050 features a heat slug on the bottom of the package body. Use of the heat slug is an integral part of the device design. Soldering it to the ground plane of the PC board will ensure the lowest possible thermal resistance for the device, and will result in the longest MTF (mean time to failure.)

A PC board layout that optimizes the benefits of the heat slug is shown in **Figure 13**. The via holes located under the body of the device must be plated through to a ground plane layer of metal, in order to provide sufficient thermal conductivity. The recommended solder mask outline is shown in **Figure 14**.

ESD Sensitivity

Electrostatic discharges can cause permanent damage to this device. Electrostatic charges accumulate on test equipment and the human body, and can discharge without detection. Proper precautions and handling are strongly recommended. Refer to the ANADIGICS application note on ESD precautions.

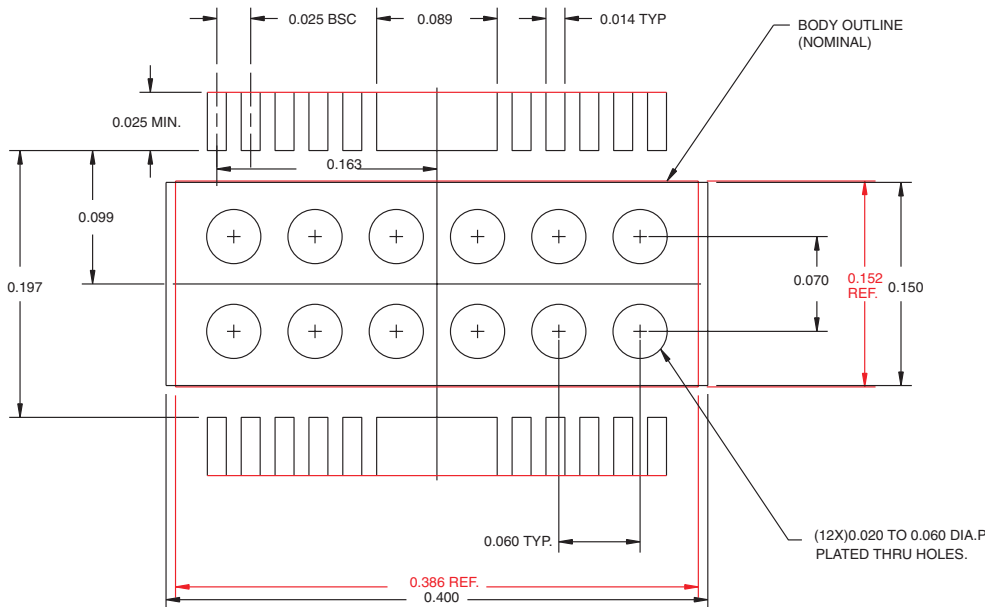
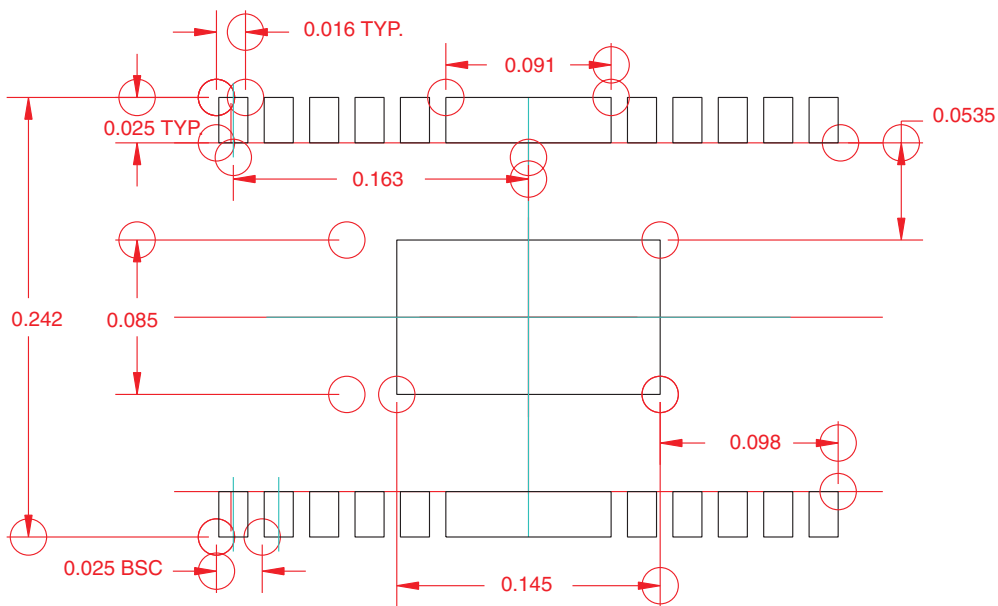

Figure 13: PC Board Layout



DIMENSIONS ARE IN INCHES

Figure 14: Solder Mask Outline

PACKAGE OUTLINE

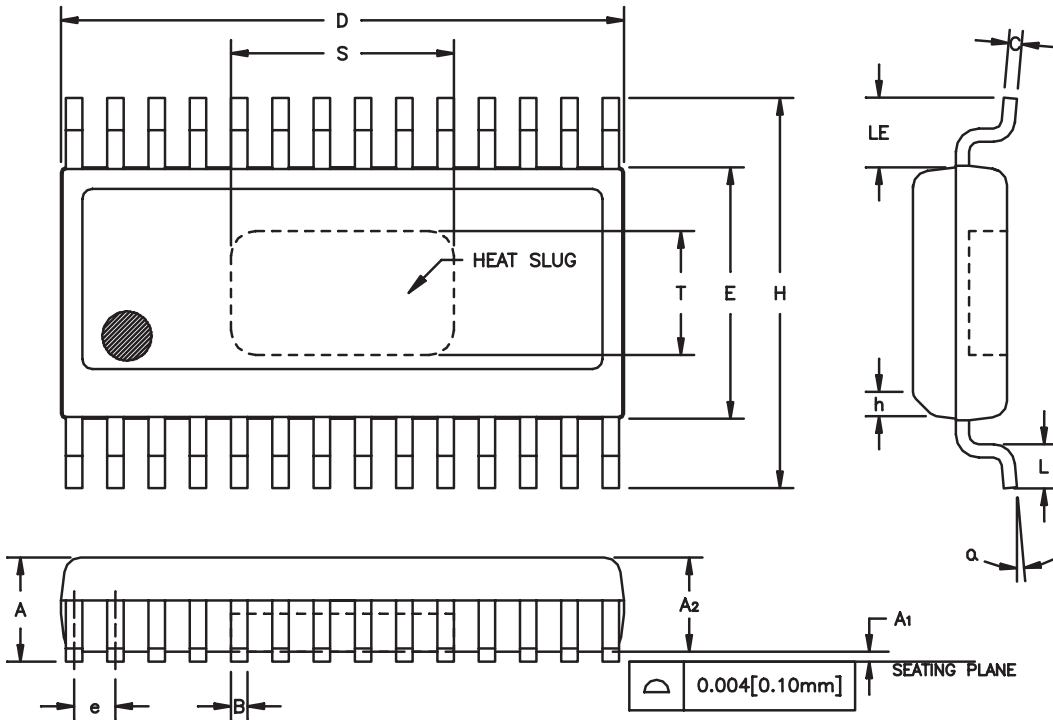

SYMBOL	INCHES		MILLIMETERS		NOTE
	MIN.	MAX.	MIN.	MAX.	
A	0.058	0.068	1.47	1.73	
A1	0.000	0.004	0.00	0.10	
A2	0.054	0.060	1.37	1.52	
B	0.008	0.014	0.20	0.35	5
C	0.007	0.012	0.18	0.30	5
D	0.385	0.393	9.78	9.98	2
E	0.151	0.157	3.84	3.99	3
e	0.025 BSC		0.64 BSC		4
H	0.228	0.244	5.79	6.20	
h	0.015x45°		0.38x45°		
L	0.016	0.032	0.41	0.81	
LE	0.042	—	1.07	—	
α	0°	8°	0°	8°	
S	0.105	0.135	2.67	3.43	6
T	0.045	0.075	1.41	1.91	6

NOTES:

1. CONTROLLING DIMENSION: INCHES
2. DIMENSION "D" DOES NOT INCLUDE MOLD FLASH, PROTRUSIONS OR GATE BURRS. MOLD FLASH, PROTRUSIONS AND GATE BURRS SHALL NOT EXCEED 0.006 [0.15mm] PER SIDE.
3. DIMENSION "E" DOES NOT INCLUDE INTER-LEAD FLASH OR PROTRUSIONS. INTER-LEAD FLASH AND PROTRUSIONS SHALL NOT EXCEED 0.010 [0.25mm] PER SIDE.
4. MAXIMUM LEAD TWIST/SKEW TO BE ±0.0035 [0.089mm].
5. LEAD WIDTH "B" AND THICKNESS "C" MAX. DIMENSION IS AFTER PLATING.
6. DIMENSIONS "S" AND "T" INDICATE EXPOSED SLUG AREA.

Figure 15: S12 Package Outline - 28 Pin SSOP with Heat Slug

COMPONENT PACKAGING

Volume quantities of the ARA05050 are supplied on tape and reel. Each reel holds 3,500 pieces. Smaller quantities are available in plastic tubes of 50 pieces.

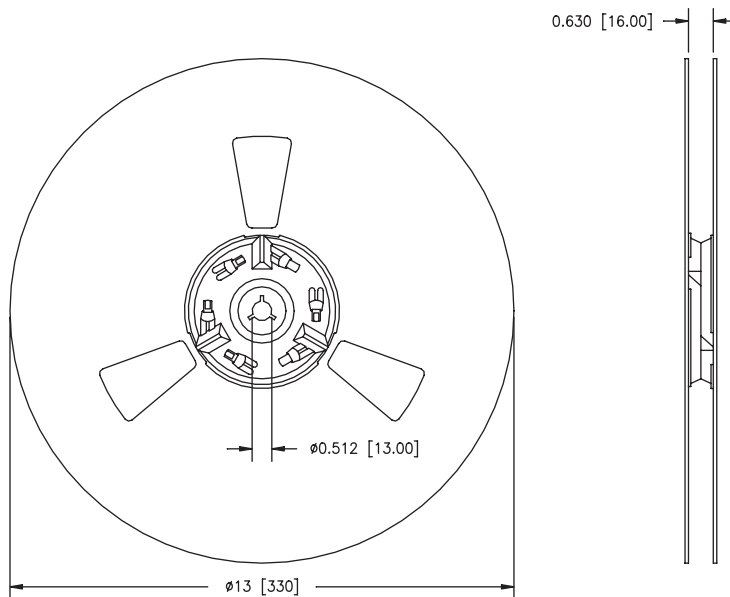

Figure 16: Reel Dimensions

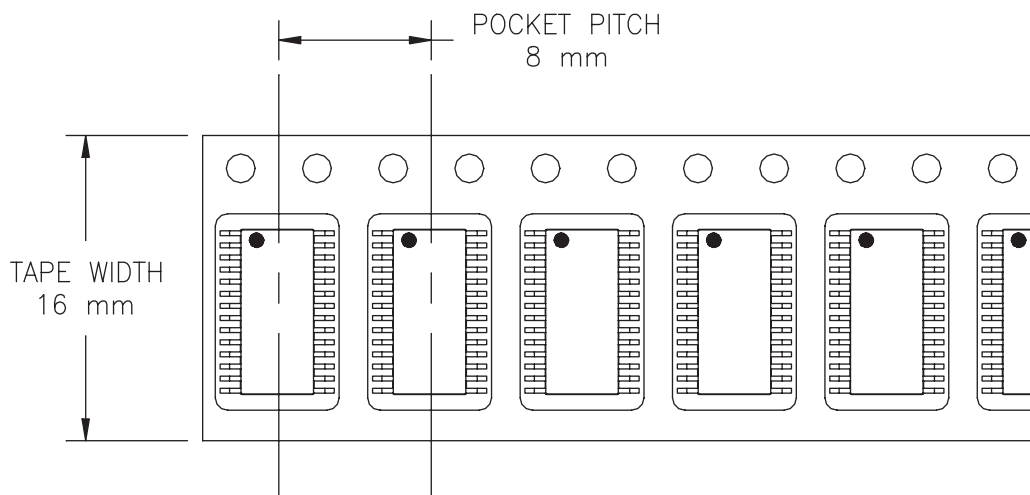

Figure 17: Tape Dimensions

ORDERING INFORMATION

ORDER NUMBER	TEMPERATURE RANGE	PACKAGE DESCRIPTION	COMPONENT PACKAGING
ARA05050S12CTR	-40 to 85 °C	28 Pin SSOP with Heat Slug	3,500 piece tape and reel
ARA05050S12C	-40 to 85 °C	28 Pin SSOP with Heat Slug	Plastic tubes (50 pieces per tube)
ARA05050RS12P1	-40 to 85 °C	RoHS-compliant 28 Pin SSOP with Heat Slug	3,500 piece tape and reel

**ANADIGICS, Inc.**

141 Mount Bethel Road
Warren, New Jersey 07059, U.S.A.

Tel: +1 (908) 668-5000

Fax: +1 (908) 668-5132

URL: <http://www.anadigics.com>

E-mail: Mktg@anadigics.com

IMPORTANT NOTICE

ANADIGICS, Inc. reserves the right to make changes to its products or to discontinue any product at any time without notice. The product specifications contained in Advanced Product Information sheets and Preliminary Data Sheets are subject to change prior to a product's formal introduction. Information in Data Sheets have been carefully checked and are assumed to be reliable; however, ANADIGICS assumes no responsibilities for inaccuracies. ANADIGICS strongly urges customers to verify that the information they are using is current before placing orders.

WARNING

ANADIGICS products are not intended for use in life support appliances, devices or systems. Use of an ANADIGICS product in any such application without written consent is prohibited.