

The most important thing we build is trust

FEATURES

C-band transponder tester:

- Multi-radar sequential test of 4 transponders
- Single or double pulse coding
- Local front panel parameters configuration
- Response rate measurement
- LCD display of configuration parameters and measurement results

C, X and Ku-Band radar receiver tester

- Three fixed frequency testing
- Emission power adjustment
- Internal and external modulation capabilities

APPLICATIONS

- GO/NO-GO Radar Transponders tests
- Transponder final test & characterization
- Calibration of Radar sensitivity and capacity



Bench Tester

TRANSPONDER TESTERS

Cobham Microwave has developed a range of Testers for C-band Transponders. These Testers provide calibration tests for most C-Band Transponders used in flight testing. The Tester sets functions to verify proper transponder operation by simulating pulse interrogations and qualifying responses per specified parameters. Testers are available in portable or bench versions.

PORTABLE TESTERS

The Radar Transponder Portable Tester (model FS248) is the appropriate tool to make aircraft GO/NO-GO radar transponder tests.

The Tester is a C-Band transponder Test Set designed to test the operability of C-Band transponders (GO/NO-GO tests). The model FS248 allows the user the ability to set the output to a single or a dual pulse interrogation, the pulse pair spacing and the RF output in the 5400 to 5900MHz frequency range.

It can be use either on the operation field, with its antenna or in a laboratory (via its N-RF connector). Tester is fully protected against rain and dust. The front panel commands consists in four buttons panel to set all the parameters. The configuration is readable via a 2x16 LCD screen and configuration is saved at turned off. The result of the test (GO/NO-GO) is given by a LED light (front panel) and a buzzer.

Model FS248 is a light tester and can be easily carried during tests processing. It can also be turned on and left alone on the ground. The operator can thus climb in the plane and turn on the transponder to check its operability directly. Tests can be achieved by one operator.

BENCH TESTERS

The Multi-Radar Transponder Tester (models FS235 & FS318) is the appropriate tool to make launch vehicle or missile transponder tests. These Testers are rackable units dedicated to be integrated in a test bench. They have added capabilities compared with portable version like response rate measurement status, frequency sweep function for transponder filter tuning, a wider dynamic range sensitivity and capacity to perform sequential test over 4 transponders. Pulse interrogation, pulse transponder and acquisition window could be displayed directly on an integrated oscilloscope.

RADAR TESTERS

Radar Testers are microwave portable generators. They are used for C, X and Ku-Band Radar tests. This Tester (model FS168) generates fixed frequency 5.9GHz, 8GHz or 12.5GHz with variable level and modulation. The operator can calibrate radar sensitivity and capacity by analyzing modulated receive signals. Power emission is adjustable by a 10dB step attenuator over a dynamic range of 60dB.

Radar & Transponder Testers

FS168, FS235, FS248, FS318

TRANSPONDER TESTERS SPECIFICATIONS

Models	FS248	FS235	FS318
Frequency range		5.4-5.9GHz Other frequency range could be proposed on request	
Frequency step	1MHz	100kHz	100kHz
Input sensitivity	-30/+56dBm	-20/+59dBm	-30/+59dBm
Output dynamic range	-40/+20dBm 10dB step	-40/+15dBm 1dB step	-80/+10dBm 0.125dB step
Interrogation modes		Single pulse, double pulse, CW, OFF	
Reply rate	95%	0 to 100%	0 to 100%
Pulse pair spacing		3 to 12µs	
Pulse width	Adjustable	0.7µs ±50ns	500ns to 1µs
PRF	Adjustable	100Hz to 3kHz 5Hz step	100Hz to 3kHz 5Hz step
Interfaces connectors		RF: 50Ω, N type Others: BNC	
Power supply	Internal battery	110/220V, 50Hz	110/220V, 50Hz
Antenna gain	+14dBi	NA	NA
Weight	6.5kg	15kg	12kg
Environmental conditions	Waterproof IP55	Laboratory	Laboratory
Other	Manual control (option RS232)	GPIB or RS232 control	Frequency sweep Delay measurement Ethernet control

Accessories supplied (FS248 model only) : carrying case, power cord
 Functional block diagram : example for FS248 model

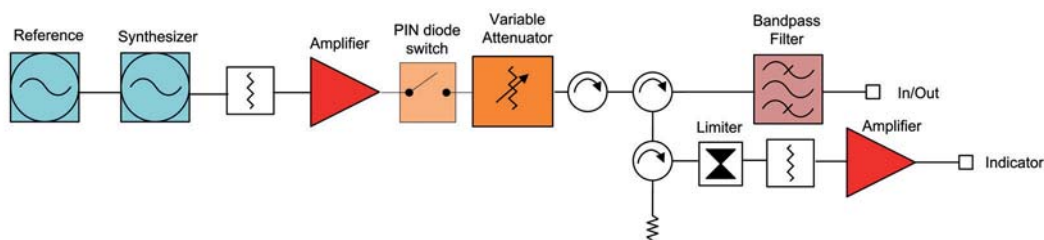

Portable Tester

RADAR TESTERS SPECIFICATIONS

Model	FS168
Fixed frequency	5.9GHz, 8GHz, 12.5GHz
Emission power	> 39dBm
Emission power adjustment	0 to 60dB with 10dB step (1dB step option)
Antenna beamwidth	15° to 35° (Frequency dependent)
Internal modulation	1kHz/1µs
External modulation	Pulse duration 0.2 to 5µs PRF 0.3 to 10kHz Input level TTL
Transmitter power control	20dB output coupling
Visible emission control	Amplifier current meter Red lamp on front panel
Target pointing	Mechanical finder
Power supply	Internal battery
Autonomy	>2 hours in CW emission Charge time < 4 hours
Weight	3.5kg
Environmental conditions	Waterproof IP52



Accessories supplied : carrying case, power cord, 12V converter and battery loader
Functional block diagram : example for FS168 model

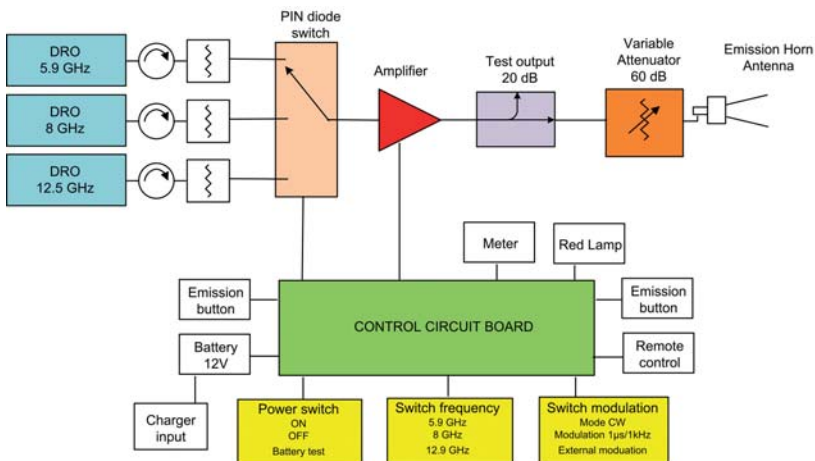

Radar Tester

Radar & Transponder Testers

FS168, FS235, FS248, FS318

COBHAM

For further information please contact:

Cobham Microwave
31 avenue de la Baltique
ZA de Courtaboeuf 1 - Les Ulis
91978 Villebon / Yvette - Cedex - France
Tel: +33(0) 69 59 98 00
Fax: +33(0) 69 59 98 02
Email: microwave.sales@cobham.com